

AUTROL Series

[Operation Manual : M2X00-E01H](#)

# ATT2100/ATT2200

## Smart Temperature Transmitter

### Operation Manual



---

Duon System Co., Ltd.

**AUTROL®** by **DUON SYSTEM Co., Ltd**  
www.autrol.com

\* Information on this manual can be changed without an advance notice.

## ATT2100 Smart Temperature Transmitter

This manual is for general user to understand the installation and operation of ATT2100 / ATT2200 Smart Temperature Transmitter efficiently.

Before handling Autrol series device, all users have to be fully understand to control or get some technical support.

Information on this manual can be changed without an advance notice.

DUON SYSTEM CO., Ltd  
60-31, Gasan-dong, Guemchon-gu, Seoul, Korea  
Tel: +82-2-860-7900  
[www.autrol.com](http://www.autrol.com)  
[autrol@duon.co.kr](mailto:autrol@duon.co.kr)

# Table of Contents

## 1. INTRODUCTION

### 1-1. USING THIS MANUAL

### 1-2. OVERVIEW OF TRANSMITTER

### 1-3. SOFTWARE COMPATIBILITY

### 1-4. TRANSMITTER COMPONENTS

## 2. HANDLING CAUTIONS

### 2-1. UNPACKING

### 2-2. MODEL AND SPECIFICATIONS CHECK

### 2-3. STORAGE

### 2-4. SELECTING THE INSTALLATION LOCATIONS

### 2-5. WATERPROOFING OF CABLE CONDUIT CONNECTIONS

### 2-6. RESTRICTIONS ON USE OF RADIO TRANSCEIVER

### 2-7. INSULATION RESISTANCE TEST AND DIELECTRIC STRENGTH TEST

### 2-8. INSTALLATION OF EXPLOSION PROTECTED TYPE TRANSMITTER

### 2-9 EMC CONFORMITY STANDARDS

## 3. TRANSMITTER FUNCTIONS

### 3-1. OVERVIEW

### 3-2. SAFETY MESSAGE

### 3-3. WARNING

### 3-4. WIRING

**3-5. FAIL MODE ALARM**

**3-6. EEPROM-WRITE ENABLE/DISABLE MODE JUMPER**

**3-7. CONFIGURATION OF ALARM AND SECURITY JUMPER PROCEDURE**

**3-8. CONFIGURATION OF ZERO AND SPAN PROCEDURE**

**3-9. CONFIGURATION OF ZERO POINT ADJUSTMENT PROCEDURE**

**3-10. COMMISSIONING ON THE BENCH WITH HHT**

**3-11. LCD MESSAGES**

**4. INSTALLATION**

**4-1. OVERVIEW**

**4-2. SAFETY MESSAGE**

**4-3. WARNING**

**4-4. COMMISSIONING ON THE BENCH WITH HAND-HELD TERMINAL**

**4-5. GENERAL CONSIDERATIONS**

**4-6. ELECTRICAL CONSIDERATIONS**

**4-7. POWER SUPPLY**

**4-8. WIRING**

**4-9. LOOP**

**4-10. WIRING INSTALLATION**

**4-11. GROUNDING**

**4-12. POWER SUPPLY VOLTAGE AND LOAD RESISTANCE**

**4-13. TEMPERATURE SENSOR INSTALLATION**

**4-14. MECHANICAL CONSIDERATIONS**

## **4-15. ENVIRONMENTAL CONSIDERATIONS**

## **5. ON-LINE OPERATION**

### **5-1. OVERVIEW**

### **5-2. SAFETY MESSAG**

### **5-3. CHECK OUTPUT**

### **5-4. BASIC SETUP**

### **5-5. DETAILED SETUP**

### **5-6. INFORMATION VARIABLE SETUP**

### **5-7. DIAGNOSITICS AND SERVICES**

### **5-8. CALIBRATION**

## **6. MAINTENANCE**

### **6-1. OVERVIEW**

### **6-2. SAFETY MESSAGE**

### **6-3. HARDWARE DIAGNOSTICS**

### **6-4. HARDWARE MAINTENANCE**

## **APPENDIX I ATT2100 SMART TEMPERATURE TRANSMITTER LCD DISPLAY CODE**

## Chapter 1 Introduction

The ATT2X00 Smart Temperature Transmitter is correctly calibrated at the factory before shipment. To ensure correct and efficient use of the instrument, please read this manual thoroughly and fully understand how to operate the instrument before operating it

- ① The contents of this manual are subject to change without prior notice.
- ② All rights reserved. No part of this manual may be reproduced in any form without DUON System's written permission.
- ③ If any question arises or errors are found, or if any information is missing from this manual, please inform the nearest DUON System sales office.
- ④ The specifications covered by this manual are limited to those for the standard type under the specified model number break-down and do not cover custom-made instrument.
- ⑤ Please note that changes in the specifications, construction, or component parts of the instrument may not immediately be reflected in this manual at the time of change, provided that postponement of revisions will not cause difficulty to the user from a functional or performance standpoint.

### 1-1 Using This Manual

The Chapters in this operating manual provide information on installing, operating, and maintaining devices from the AUTROL Model ATT2100 Smart Temperature Transmitter. The Chapters are organized as follows.

#### Chapter 2 Handling Cautions

Chapter 2 provides instruction on unpacking, Storage and Selecting the installation locations. Also, installation of explosion protected type transmitters at site and about EMC Conformity standards.

#### Chapter 3 Transmitter Functions

Chapter 3 contains in consideration of handling Model APT3100 Smart Pressure Transmitters.

#### Chapter 4 Installation

Chapter 4 contains mechanical, environment consideration and electrical installation instructions on the Model ATT2100 Smart Temperature Transmitters.

#### Chapter 5 On-line Operation

Chapter 5 describes the configuration the parameter how to use variety of the Model ATT2100 Smart Temperature Transmitters' software function and configuration.

#### Chapter 6 Maintenance

Chapter 6 contains hardware diagnostics, troubleshooting and maintenance task.

## 1.2 Overview of Transmitter

Autrol® Smart Temperature Transmitter based in a microprocessor is the temperature transmitter, has temperature sensors such as Thermocouple, RTD, mV, Resistance for temperature measurement. ATT2100 has a true draft analog range from 0 to 20mA offering that feature that a temperature range or after convert analog range to HART (Communication) digital signal transmit for control systems like DCS, PLC. This Model has explosion protected type and high precision, better reliability and is available on digital communication for the use remotes communication system.

This transmitter is enabled in HART communication with Host, HHT (HART Hand-Held Terminal) or PC Configurator. Thus, transmitter various variables in host is enable to be changed, configured and tested calibrated by users. For the HART Communication between DC Power Supply and Transmitter has to terminate 250~ 600 Ohm.

## 1.3 Software Compatibility

Autrol® Smart Transmitter's software is implemented and complemented if necessary. Uses of the transmitter will not be a compatibility software is contained in the host of the HHT(Model 275 HART Communicator). In this case contact us for software DD(Device Descriptor) to be able to use with the transmitter, you must to use loading in HHT, etc.

There may be some differences on supported functions as to Firmware Revision of transmitter. This manual is based on Firmware Revision 58. Function deviations as to firmware Revision are same as under box

FUNCTION	Function Supports			
	ZERO / SPAN Botton		Autrol PC/PDA	HART 275/375
	Before Rev. 58	Rev. 58		
ZERO/SPAN	●	●	●	●
ZERO TRIM	●	●	●	●
ZERO Adj	●	●	●	●
Units set	×	●	●	●
Range set	×	●	●	●
Damping set	×	●	●	●
LCD Decimal set	×	●	●	Δ

● : Supported.

× : Not Supported

Δ : Supported but update required

## 1.4 Transmitter Components

The components and figure of Autrol® Smart Temperature Transmitter ATT2100 is as follow.

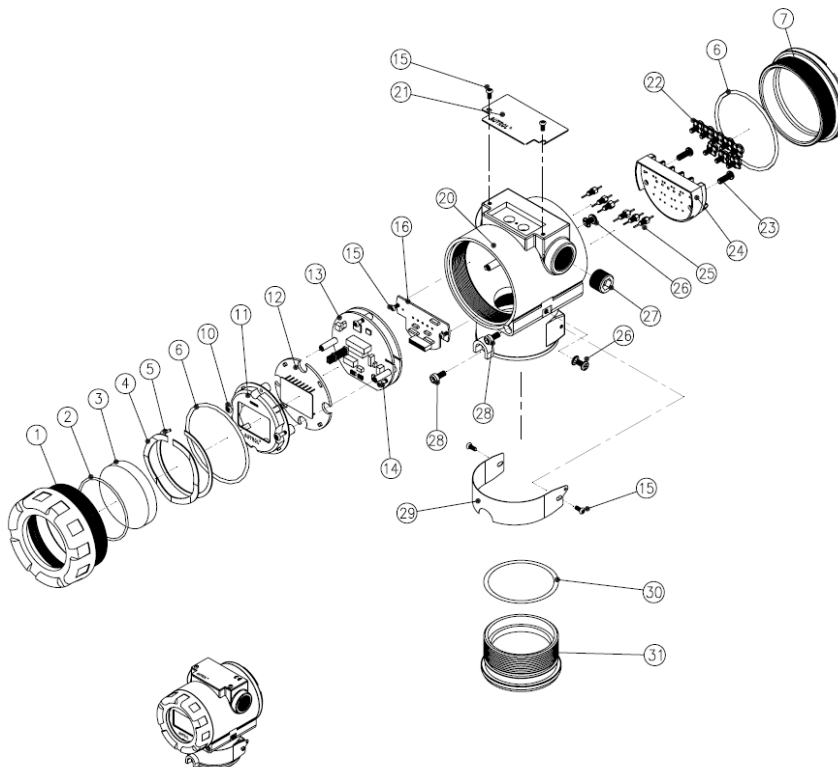
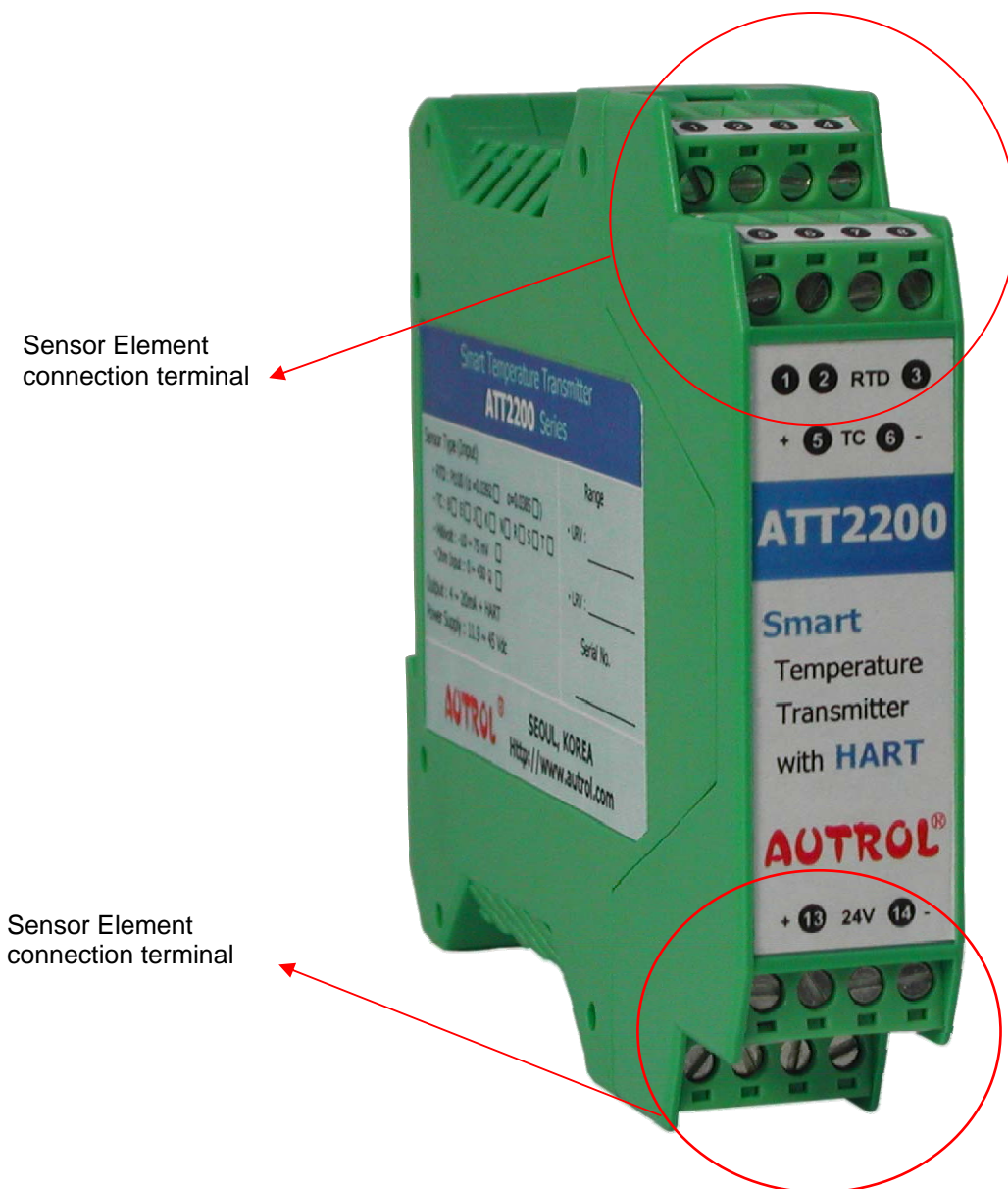

Figure 1-1. Model ATT2100 Transmitter Expoded View (Housing)

P.N	PART NAME	P.N	PART NAME
1	FRONT COVER	20	HOUSING
2	O-RING/GLASS	21	NAMEPLATE
3	GLASS	22	TERMINAL SCREW
4	WAVE WASHER	23	SCREW/TERMINAL BLOCK
5	C-SNAP RING	24	TERMINAL BLOCK
6	O-RING/COVER	25	EMI FILTER
7	REAR COVER	26	SCREW
10	SCREW/LCD	27	PIPE PLUG
11	LCD COVER	28	SCREW
12	LCD BOARD	29	TAGPLATE
13	MAIN BOARD	30	O-RING/SENSOR MODULE
14	SCREW/MAIN BOARD	31	SENSOR MODULE BOTTOM
15	SCREW		
16	TERMINAL BOARD		

Figure 1-2. TRANSMITTER COMPONENTS





## Chapter 2 Handling Cautions

This chapter consists of cautions for transmitter handling and storage, selection of installation locations, insulation and explosion structure, etc.

### [Quick Reference Manual]

Step	Jog	Job Details	Instrument
1	Unpacking	a) Unpack transmitter packing	
2	Model and Specifications Check	a) Make sure whether the delivered transmitter is same as options attached on its nameplate	
3	Storage	a) Places not exposed to water, non-vibration and non-impact area b) Ambient temperature 25 deg C and relative humidity 65% RH	

4	Calibration on a Calibration Room	a) Basic Configuration b) Input RTD &TC, TC Cold Junction Calibration, DAC Trim	HHT, Galvanometer
5	Installation Location	a) Where ambient temperature is not fluctuated b) Where corrosion happens by chemical materials, etc. c) Where vibration and impact is not severe d) Where non-explosion area is matched on explosionproof regulations e) Where maintenance is very easy	(Engineering)
6	Mechanical Considerations	a) Where transmitter can be handled easily	(Engineering)
7	Electrical Considerations	a) Connect 24 Vdc (Power Supply is 11.9 Vdc – 45 Vdc) b) For HART communication, total resistance on transmitter terminal loop should be 250 – 550 Ohm.	(Engineering)
8	Mounting and Installation	a) For mounting transmitter, an appropriate bracket should be used. b) Transmitter should be fixed well against swing.	(Mounting and Installation)
9	Calibration on Spot	a) Input mV value at 0 °C, and compensation (RTD: 100Ω, TC: according to sensor type 0 °C mV value) b) Make sure that PV value of transmitter is zero and current is 4 mA.	HHT, Galvanometer
10	Operation	a) Make sure whether transmitter operates well or not	Eye or HHT

## 2.1 Unpacking

When moving the transmitter to the installation site, keep it in its original packaging. Then, unpack the transmitter there to avoid damage on the way.

## 2.2 Models and Specifications Check

The model name and specifications are indicated on the nameplate to the case. Please check your specification and wanted model.

## 2.3 Storage

The following precautions must be observed when storing the instrument, especially for a long period.

(1) Select a storage area that meets the following conditions:

- (a) It is not exposed to rain or water.
- (b) It suffers minimum vibration and shock.
- (c) If possible, it is preferable at normal temperature and humidity (approx. 25°C, 65% RH).

However, it has an ambient temperature and relative humidity within the following ranges.

- Ambient Temperature: -40 ~ 85°C (without LCD module)  
-30 ~ 80°C (with LCD module)
  - Relative Humidity: 5% ~ 98% RH (at 40°C)
- (2) When storing the transmitter, repack it as nearly as possible to the way it was packed when delivered from the factory.
  - (3) Make sure before storing that the sensor module, flange, housing are securely mounted.

## 2.4 Selecting Installation Locations

The transmitter is designed to withstand severe environmental conditions. However, to ensure stable and accurate operation for many years, the following precautions must be observed when selecting an installation location.

- (1) Ambient Temperature  
Avoid locations subject to wide temperature variations or a significant temperature gradient. If the location is exposed to radiant heat from plant equipment, provide adequate insulation or ventilation.
- (2) Ambient Atmosphere  
Avoid installing the transmitter in a corrosive atmosphere. If the transmitter must be installed in a corrosive atmosphere, there must be adequate ventilation as well as measures to prevent intrusion or stagnation of rainwater in conduits. Moreover, there should be appropriate ventilation preventing corrosion by rain gathered on conduit.
- (3) Shock and Vibration  
Select an installation site suffering minimum shock and vibration (although the transmitter is designed to be relatively resistant to shock and vibration)
- (4) Installation of Explosion-protected Transmitters  
Explosion-protected transmitters can be installed in hazardous areas according to the gas types for which they are certified.
- (5) Select a place that transmitter maintenance is very easy.

## 2.5 Waterproofing of Cable Conduit Connections

Apply a non-hardening sealant (silicone or tape, etc.) to the threads to waterproof the transmitter cable conduit connections.

## 2.6 Restrictions on Use of Radio Transceivers

### ▲ Warning

- ◆ Although the transmitter has been designed to resist high frequency electrical noise, if a radio transceiver is used near the transmitter or its external wiring, the transmitter may be affected by high frequency noise pickup. To test for such effects, bring the transceiver in use slowly from a distance of several meters from the transmitter, and observe the measurement loop for noise effects. Thereafter, always use the transceiver outside the area affected by noise.

## 2.7 Insulation Resistance Test and Dielectric Strength Test

Since the transmitter has undergone insulation resistance and dielectric strength tests at the factory before shipment, normally these tests are not required. However, if required, observe the following precautions in the test procedures.

(1) Do not perform such tests more frequently than is absolutely necessary. Even test voltages that do not cause visible damage to the insulation may degrade the insulation and reduce safety margins.

(2) Never apply a voltage exceeding 500 Vdc (100 Vdc with an internal lightning protector) for the insulation resistance test, nor a voltage exceeding 500V AC (100V AC with an internal lightning protector) for the dielectric strength test.

(3) Before conducting these tests, disconnect all signal lines from the transmitter terminals. Perform the tests in the following procedure.

### (4) Insulation Resistance test

(a) Short-circuit the + and - SUPPLY terminals in the terminal box.

(b) Turn OFF the insulation tester. Then connect the insulation tester plus (+) lead wire to the shorted SUPPLY terminals and the minus (-) lead wire to the grounding terminal.

(c) Turn ON the insulation tester power and measure the insulation resistance. The voltage should be applied short as possible to verify that insulation resistance is at least 20MΩ.

(d) After completing the test and being very careful not to touch exposed conductors disconnect the insulation tester and connect a 100kW resistor between the grounding terminal and the short-circuiting SUPPLY terminals. Leave this resistor connected at least three second to discharge any static potential. Do not touch the terminal while it is discharging.

### (5) Dielectric Strength Test

(a) Short-circuit the + and - SUPPLY terminals in the terminal box.

(b) Turn OFF the dielectric strength tester. Then connect the tester between th shorted SUPPLY terminal and the grounding terminal. Be sure to connect the grounding lead of the dielectric strength tester to the ground terminal.

(c) Set the current limit on the dielectric strength tester to 10mA, then turn ON the power and gradually increase the tester voltage from '0' to the specified voltage.

(d) When the specified voltage is reached, hold it for one minute.

(e) After completing this test, slowly decrease the voltage to avoid any voltage surges.

## 2.8 Installation of Explosion Protected Type Transmitters

### 2.8.1 KOSHA Certification

Caution for KOSHA Flameproof is following type.

[Note1] Model ATT2100 diaphragm sealed for potentially explosive atmosphere:

- Type of Protection and Marking Code: Ex d II C T6
- Temperature Class: T6
- Ambient Temperature: -20 ~ 60°C
- Process Temperature: Max. 80°C

[Note2] Electrical Data

- Supply Voltage: Maximum 45 Vdc
- Output signal: 4 ~ 20mA, maximum 22mA

## [Note3] Installation

- All wiring shall comply with local installation requirement.
- The cable entry devices shall be of a certified flameproof type, suitable for conditions of use.

## [Note4] Operation

- Wait one minute after power -disconnection, before opening the enclosure.
- Take care not to generate mechanical spark when access to the instrument and peripheral devices in hazardous location.

## [Note5] Maintenance and Repair

- The instrument modification or parts replacement by other than authorized representative of DUON System is prohibited and will void KOSHA Flameproof.

## 2.8.2 KEMA / ATEX Certification

ATEX Certification number : KEMA08ATEXxxxx

CE 0344  II 2 G

Note 1. Model ATT2100 for potentially explosive atmosphere

- Ex d IIC T6... T4
- Operating Temperature :  $-20^{\circ}\text{C} \leq T_{\text{amb}} \leq +60^{\circ}\text{C}$
- T6 for process  $\leq 85^{\circ}\text{C}$ ;
- T5 for process  $\leq 100^{\circ}\text{C}$ ;
- T4 for process  $\leq 130^{\circ}\text{C}$ ;

Note 2. Electrical Data

- Supply Voltage : 11.9 to 42 Vdc
- Output Signal : 4 to 20 mA + HART

Note 3. Electrical Connection : 2 x 1/2-14NPT Female

Note 4. ATT2100 ATEX Certification is according to the below standards

EN 60079-0 : 2006

EN 60079-1 : 2007

Note 5. Installation

- All wiring shall comply with local installation requirement.
- The cable glands and blanking elements shall be of a certified flameproof type, suitable for the condition of use and correctly installed. Also those devices should be endured at the  $130^{\circ}\text{C}$ .
- Housing Ground must be followed to "local electrical codes". The most efficient ground procedure is to connect directly to the earth as least impedance.
- How to Housing Ground:
- \* Internal Ground Connection: Internal ground connection screw is located in terminal in housing, the screw can be identified as ground sign.
- \* External Ground Assembly: This is located in the right side of housing and identified as ground sign. (For grounding use a cable lug)
- When use tubing, Stopping boxes must be connected with the wall of housing directly.
- Tubing is installed a minimum of 5 threads.
- Sensor is to be threaded a minimum of 7 threads and prevented from turning by tightening the housing rotation set screw.
- Do not disassemble flameproof Joints but in an unavoidable case to disassemble it or need the specification of flameproof Joints, contact the manufacturer before doing.

**Note 6. Operation**

- WARNING-DO NOT OPEN WHEN AN EXPLOSIVE ATMOSPHERE MAY BE PRESENT
- Take care not to generate mechanical spark when access to the instrument and peripheral devices in hazardous location.

**Note 7. Maintenance and Repair**

- The instrument modification or parts replacement by other than authorized representative of DUON System is prohibited and will void KEMA/ATEX Explosion-proof / Flame-proof.

## 2-8-3. FM Certification

### HAZARDOUS LOCATION ELECTRICAL EQUIPMENT

ATT2100-abcd. Temperature Transmitters.

XP/I/1/ABCD/T6 Ta = 60°C;

DIP/II, III/1/EFG/T6 Ta = 60°C;

a = Transmitter Type : S, D

b = Electrical Connection : 1

c = Hazardous Location Certification : F1.

d = Option : BA, BF, C7, M1, X

Equipment Rating :

Explosionproof for use in Class I, Division 1, Groups A, B, C and D;

Dust-Ignition proof for Class II, Division 1, Groups E, F and G;

Dust-ignition proof for Class II, Division 1

"T6, see instruction for temperature code if process temperature above 85°C"

Ambient Temperature : -20 to 60°C

Enclosure : indoors and outdoors, NEMA Type 4X

Conduit seal required within 18" for Group A only.

Nonincensive for Class I, Division 2, Groups A, B, C and D ; Class II, Division 2,

Groups E, F and G ; Class III, Division 1, Temperature Code T4

Ambient Temperature : -20 to 60°C

Enclosure : indoors and outdoors, NEMA Type 4X

## 2.9 EMC Conformity Standards

EMI (Emission): EN55011

EMS (Immunity): EN50082-2

DUON System recommends customer to apply the Metal Conduit Wiring or to upset he twisted pair Shield Cable for signal wiring to conform the requirement of EMC Regulation, when customer installs AUTROL Series Transmitters to the plant.

## Chapter 3 Transmitter Functions

### 3.1 Overview

This Chapter contains information on operating Model ATT2100. Tasks that should be performed on the bench priori to installation are explained in this chapter.

## 3.2 Safety Message

Procedures and instructions in this chapter may require special precautions to ensure the safety of the personal performing the operations. Information that raises potential safety issues is indicated by warning symbol(▲). Refer to the following safety messages before performing an operation preceded by this symbol.

## 3.3 Warning

▲ Warning
<p><b>Explosion can result in death or serious injury:</b></p> <ul style="list-style-type: none"><li>◆ Do not remove the transmitter covers in explosion environments when the circuit is alive.</li><li>◆ Check transmitter to install according to Intrinsically safe regulation before HHT connect to Transmitter in explosive environment.</li><li>◆ Transmitter covers must be fully engaged to meet explosionproof requirements.</li></ul>

▲ Warning
<p><b>Electrical can result in death serious injury:</b></p> <ul style="list-style-type: none"><li>◆ The qualification which is educated only the person whom it prepares will be able to establish the transmitter.</li></ul>

▲ Warning
<p><b>Electrical can result in death serious injury:</b></p> <ul style="list-style-type: none"><li>◆ Avoid contact with the leads and terminals. High voltage that may be present on leads can cause electrical shock.</li></ul>

### 3.4 Connection of Sensor

ATT2100 Temperature Transmitter can input sensors such as RTD, Thermocouple(TC) and Resistance. In case RTD, 2Wire/3Wire and 4Wire Sensor connection is applicable. Also, 2Wire TC(B, E, J, K, N, R, S, T) Sensor input is applicable. Below pictures are present sensor connections using RTD & TC. Ex) In case RTD 3Wire, common line connect to terminal No. 1, 2.

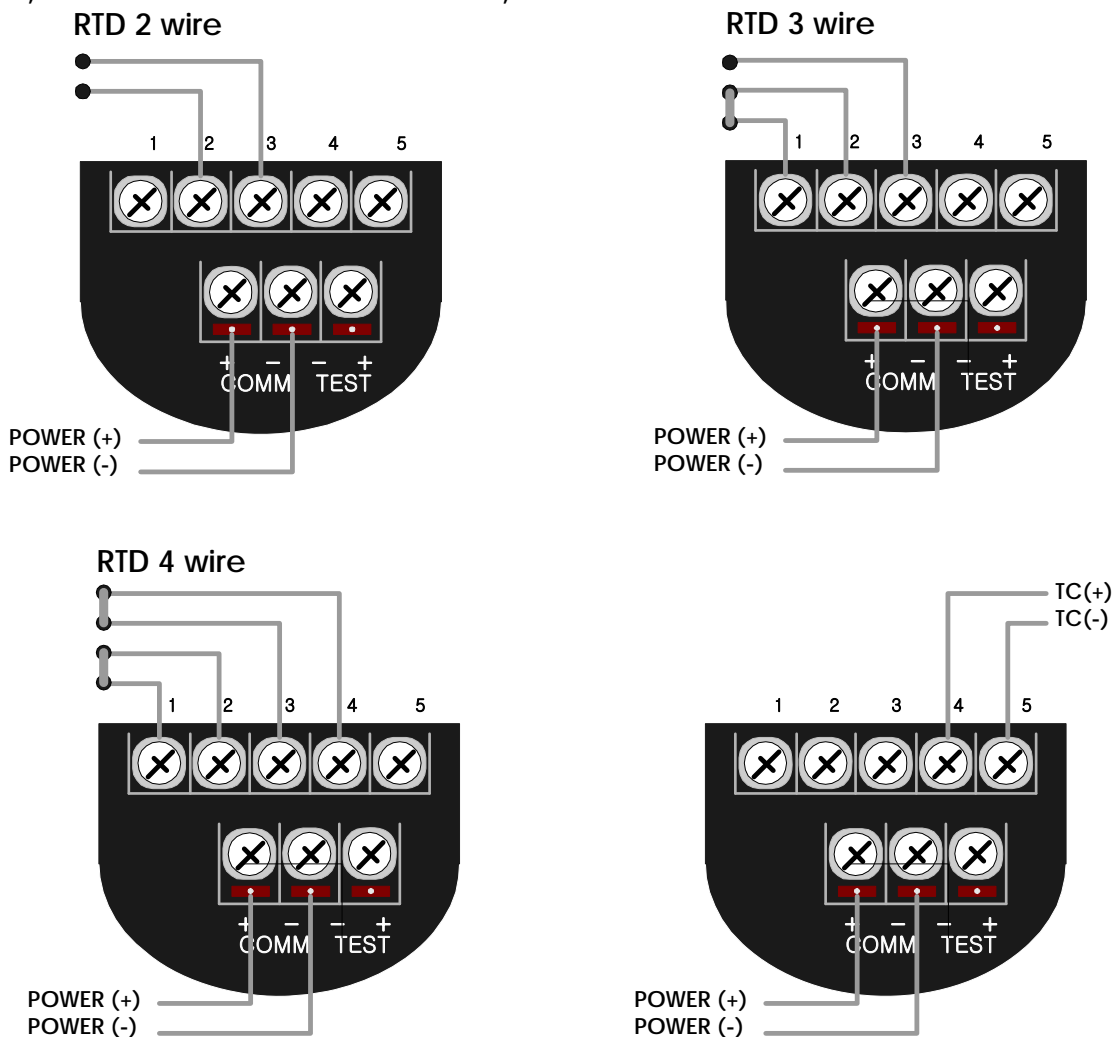
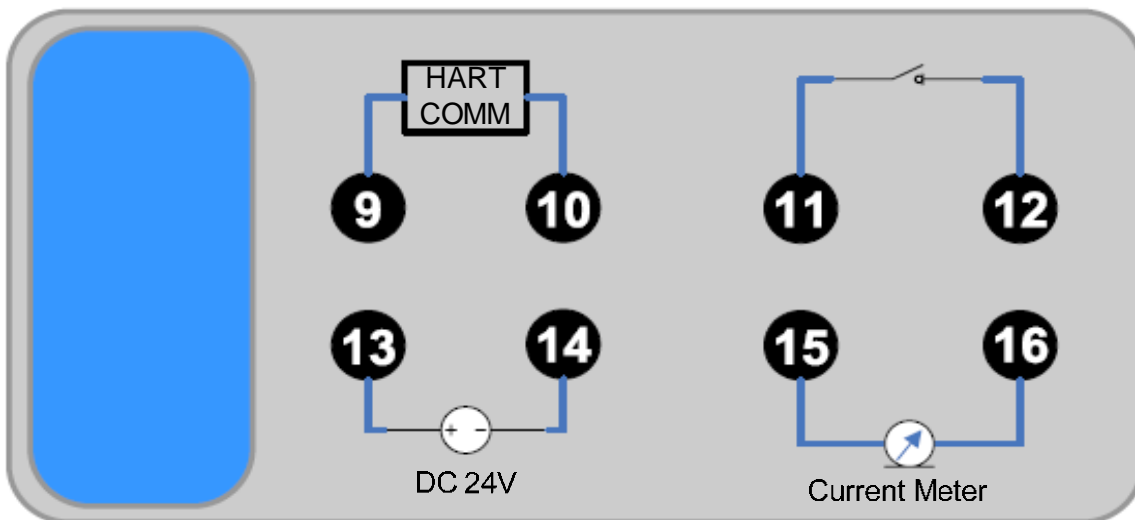

Figure 3-1. ATT2100 Temperature Transmitter Sensor Connections





ATT2200 connector & HART communication.

### 3-5. Fail Mode Alarm

AUTROL® Smart Temperature Transmitter automatically and continuously performs self-diagnostic routines. If the self-diagnostic routines detect a failure, the transmitter drives its output outside of the normal saturation values. The transmitter will drive its output low(down) or high(up) based on the position of the failure mode alarm jumper . See Table 3.1 for Output values.

[Table 3-1 Standard Alarm and Saturation Value]

Level	4~20mA Saturation	4~20mA Alarm
Low/Down	3.9 mA	≤ 3.8 mA
High/Up	20.5 mA	≥ 21 mA

Fail Mode Select Jumper Switch has in LCD Module and Main CPU Module and Jumper Switch Line is connected circuitally. In case of Not LCD Module, we can use CPU Module's Fail Mode Select Jumper Switch and In case of LCD Module we can use LCD Module's Jumper Switch. In this case, CPU Module is selected "Down" side. No selected we can select "Down" side. (Jumper Select Switch is followed in Figure 3-2, 3-3)

Select Fail Mode	Both LCD Module and CPU Module		Only CPU Module
	CPU Module	LCD Module	CPU Module
Fail Down	Down	D	D
Fail Up	Down	U	U
	Up	U or D	

Table 3-2. Fail Mode





Fail Mode and EEPROM Write Selection Switch on CPU Board	
	
EEPROM Writing [Down of Left]	Alarm Down (4mA) [Down of Right]
	
EEPROM Protect [Up of Left]	Alarm Down (20mA) [Up of Right]

Figure 3-1. Fail Mode and EEPROM-Write Selection Jumper Switch

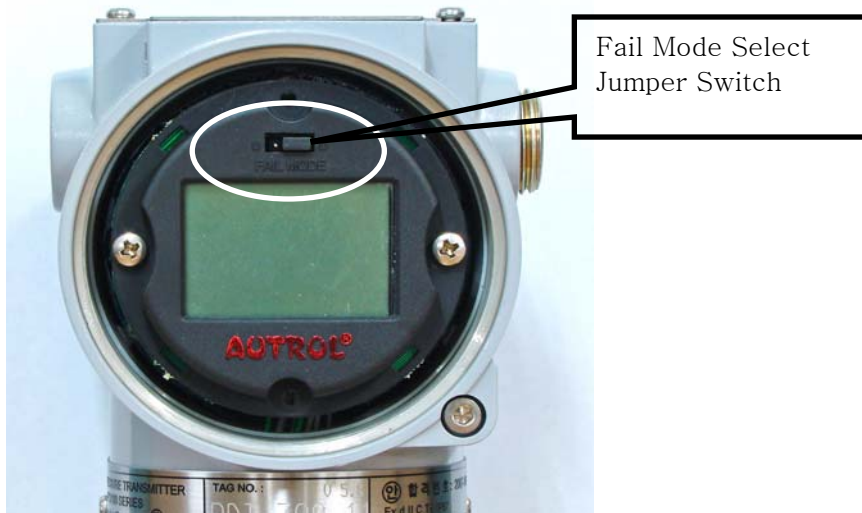

Figure 3-2 Fail Mode Selection Jumper Switch of LCD Module

### 3.6 EEPROM-Write Enable / Disable Mode Switch

There is the EEPROM (Electrically Erasable Programmable ROM) restoring various configuration variables in Transmitter. For protect to change configuration variable data in software, hardware side there is Write-Protect Mode and Jumper Switch selected it segmented "EEP-Write DIS / EN " in Main CPU Module. Thus if you connect Jumper to DIS you can't change configuration data in EEPROM, when you connect Jumper to EN you can change configuration data in EEPROM. No connected Jumper, it is classified EN. At the factory before shipment, it is configured "EN". (Following figure 3-4)



Figure 3-3. Jumper Switch

- Dip Switch Selection -

Left 1(WR-EN) : EEPROM WRITE En/Disable Setting

Right 2(DOWN) : Fail Mode ALARM Setting

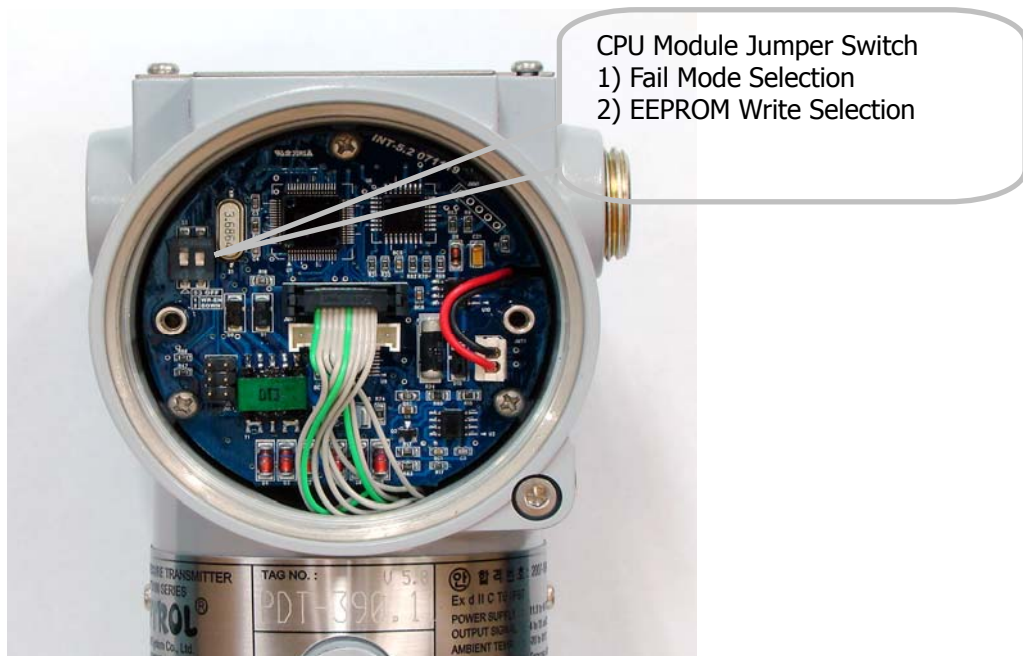

Figure 3-3. CPU Module Fail Mode, EEPROM-Write Selection Jumper Switch

There are two security methods in ATT2100. Following this.

- (1) Security Jumper: protect to writing configuration parameters of transmitter.
- (2) Physical removing Zero and Span Magnetic Buttons of Transmitter: you are not able to regulate Zero and Span in Local.

### 3.6.1 Security Jumper (EEPROM Write Protect)

Protect to change Configuration Parameter of transmitter to Write Protect Jumper.

### 3.6.2 Zero and Span Magnetic Button

To remove Magnetic Button, you can't configure Zero and Span in Local.

## 3.7 Configuration of Alarm and Security Jumper Procedures

To change Jumper's position, follow this.

- (1) If install the transmitter, cutoff power.
- (2) Open the housing front side covers. In case Power Supply, don't open the covers of transmitter
- (3) After turn off Jumper, turn on at wanted position.
- (4) Close the housing covers. You must fully engage to meet explosion proof requirements

## 3.8 Configuration of Zero and Span Procedures

There are ZERO and SPAN Buttons when the nameplate opened of the transmitter. For the previous version of transmitter, ZERO, SPAN, ZERO TRIM and ZERO ADJ. functions were supported using ZERO / SPAN Buttons. But, from the version of 58, Units, Range, Damping, LCD decimal set functions are included. Also, the procedure is changed as below.

But ZERO and SPAN set function is same as before Revision of 58.

Using functions which supported by buttons,

- (1) Zero/Span Button mounted in Transmitter.
  - (2) HHT Configurator by HART Communication (following chapter 4)
- \*\* Refer to "275 Hart Communicator User Guide" on Appendix II for details.

Zero/Span configuration process by Zero/Span Button of transmitter is following this.

- (1) Release to both sides bolts of Name Plate in the upper part of transmitter and if push down right of Name Plate, appear to Zero/Span Button (following figure 3-5)

#### (2) Zero Configurations

Set the current process value for Lower Range Value (4 mA).

Put purposed pressure for zero over 10 seconds and push Zero Button over 5 seconds. Then show "Zero" in LCD window. After checking this message, take off the finger from the button. Push the button over 3 seconds after 1 second passes. Then show "-ZE-" in LCD window. By this message, all zero configurations have finished. If the works has failed, show "SPEr" or "SEtE" in LCD window.

#### (3) Span Configurations

Set the current process value for Upperr Range Value (20 mA).

Put purposed pressure for zero over 10 seconds and push Span Button over 5 seconds. Then show "SPAN" in LCD window. After checking this message, take off the finger from the button. Push the button over 3 seconds after 1 second passes. Then show "-SP-" in LCD window. By this message, all zero configurations have finished. If the works has failed, show "SPEr" or "SEtE" in LCD window.

- Error Message

- "SPEr" : In case, Setting Value is over Sensor Limit Range or Less Minimum SPAN

- "SEtE" : In case, Setting Value is not written on Memory
- "ZtEr" : In case, Setting Zero Trim value is 10% over Sensor Max Span
- "bEr1" : In case, Zero/Span and Zero Trim functions are stopped in the middle of work  
(In case, Button is put only one time or put continuously) This message is present

for Button Error

### 3.9 Configuration Zero Point Adjustment

Zero Point Adjustment means to configure PV value which output after Zero Trim. At last, Zero point Adjustment is to configure a current PV Value for another value, which is not zero, by configuring Offset value of zero point. This is for configuring a current displayed value for a desiring process value without making process value zero. Especially, in case of configuring level value is very difficult to make Sensor Zero Trim, this adjustment is very convenient to configuring a current value for a desiring value.

PV\_raw : Value that transmitter calculates signal from sensor

PV : Value that transmitter finished Sensor Zero Trim or Zero Point Adjustment

Offset : Value calculated when Sensor Zero Trim or Zero Point Adjustent is done

$$PV = PV\_raw + Offset$$

- a) In case, Sensor Zero Trim :  
 $PV = 0 = PV\_raw + Offset$   
 (In result, Offset = - PV\_raw)
- b) In case, Zero Point Adjustment  
 $PV = PV\_raw + Offset$   
 (Offset is variable. Therefore, PV value and Zero point can be configured by changing Offset value).

There are two ways for Zero Point Adjuntment of ATT2100

A. Using Zero/Span button attached on transmitter

B. Using HART communicator, HHT, etc.

*\* For more information and details, please refer to 275 User Guide*

The below guide is a Zero Point Adjustment procedure using Zero/Span button

- 1) Loosen both bolts of Name Plate on upside transmitter and push the right end of Name Plate back a little bit(Figure 3-5)
- 2) Apply necessary pressure and push Zero and Span button simultaneously over 3 seconds. Then show "Z-tr" in LCD window. And continuously push Zero and Span buttons over 3 seconds again. Then show "Z-AD" in LCD window. After making sure this message, 0.01% diminishes whenever

Zero button is pushed, and 0.01% increases whenever Span button is pushed. Pushing button continuously makes speed fast or slow. If you push Zero/Span button over 3 seconds or do not push any button over 30 seconds. "-Zo-" message shows in LCD window. By this message, all procedures finish. Range for Zero Point Adjustment is permitted within 100% of Calibrated Span.

3) Close cover of Name Plate and lock both bolts

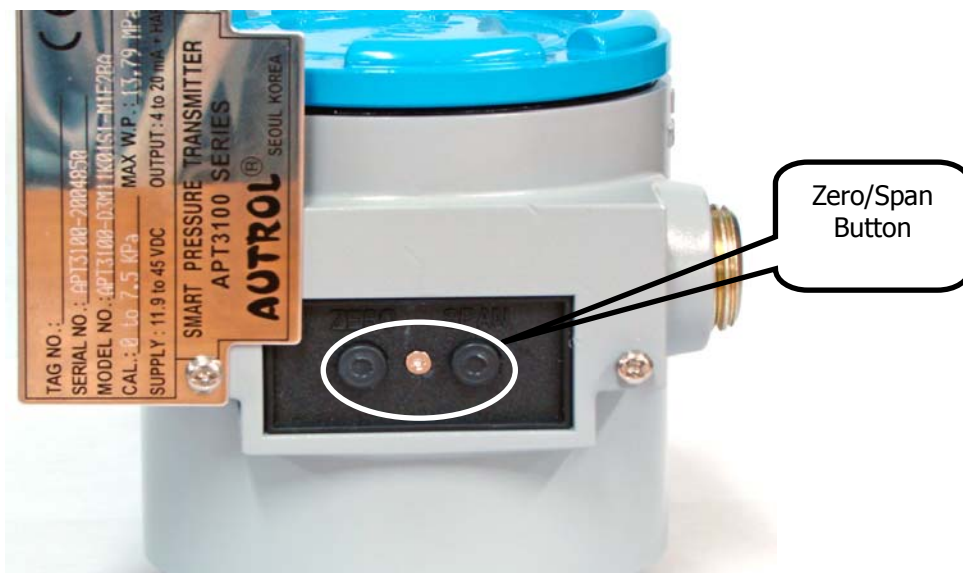
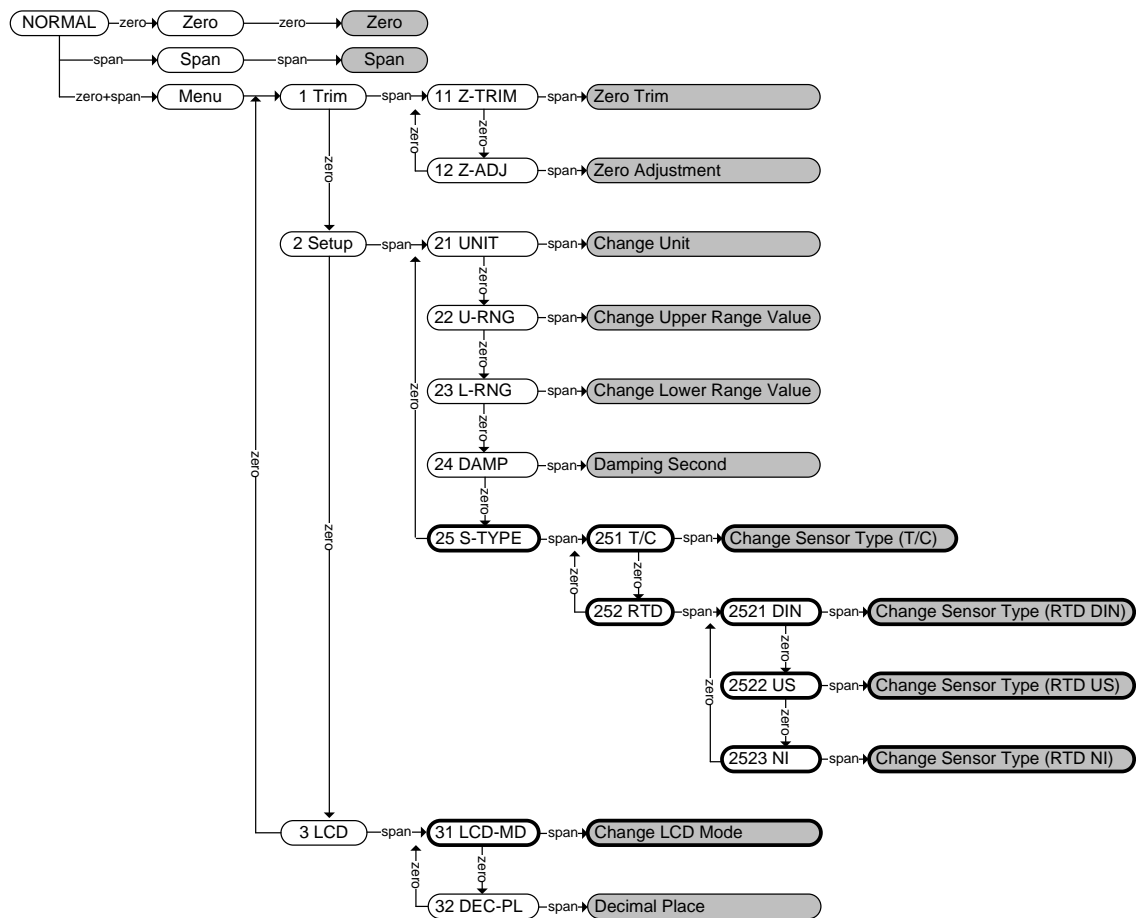

Figure 3-4 Transmitter's Zero/Span configuration Button

- Refer to Appendix I for Button Error and LCD Display Message

Menu Tree of ATT2100 for external button function.



### 3.10 Shop Commissioning using HHT

Commissioning consists of testing the transmitter, testing the loop, and verifying transmitter configuration data. APT-3100 Pressure Transmitter may be commissioned using HHT of HART supported either before of after installation.

▲ If you connect "TEST" pin, it's not communicated. If it doesn't exposed electronics circuits after install, you must connect all Jumper of transmitter in the shop commissioning level. Analog output of transmitter is 4~20 mA, thus it requires Power Supply at 11.9 V ~ 45 Vdc(ATEX:11.9 to 42Vdc) and Ampere meter for measuring output current. You must connect 250~550 ohm resistor in Power Loop for HART Communication and HHT or PC Configurator.

#### POWER / SIGNAL CONNECTIONS

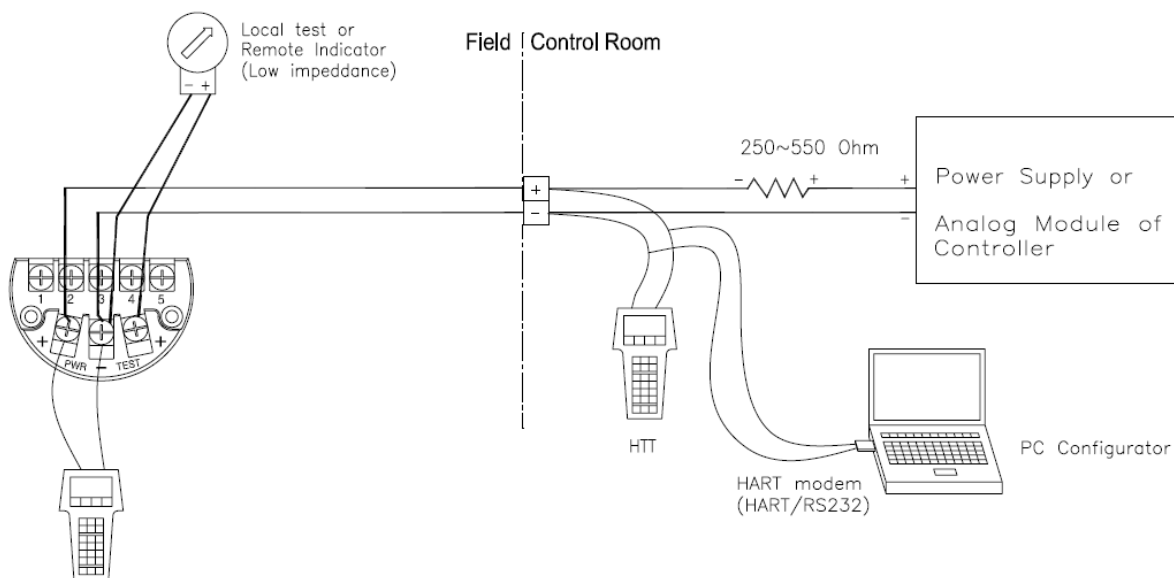

1. HHT (HART Communicator) or PC Configurator may connected at any termination point in the signal loop.
2. HART Communication requires a loop resistance between 250 ~ 550 ohm @ 24Vdc.
3. Transmitter operates on 11.9 to 45.0 Vdc transmitter terminal voltage.

[Applied Power]

- \* 11.9 ~ 45.0 Vdc for G€ tion
- \* 17.4 ~ 45.0 Vdc for HART Communication
- \* 17.4 ~ 42.0 Vdc for CSA Approval (On Processing)

Figure 3-6 Connection the transmitter to HHT



### 3-11. Description of LCD Messages

ATT-2100 Transmitter inform any cautions and failures to user through LCD during operation. Measured Value(Temperature, Resistance, Voltage, etc) and Unit(°C, °F, R, T, mV, ohm, etc) will be shown on LCD during normal working.

Generally below LCD Messages will be shown during normal working condition or setting inner memory.

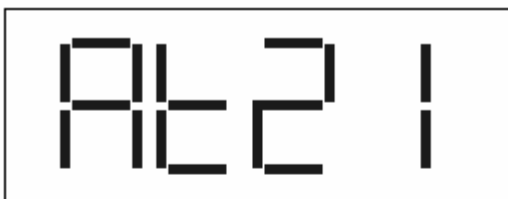

This message will be shown at initial time when power is supplied(Meaning of ATT-2100)



This message will be shown when resetting of CPU inner EEPROM Data, and transmitter will be reset when the resetting procedure is done.

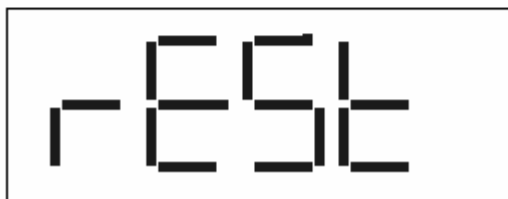

Shown when above EEPROM resetting or Transmitter reoperation according to reoperation message.

Below messages present for self diagnostic functions or failures during operating, back to normal

condition when the failures are removed.

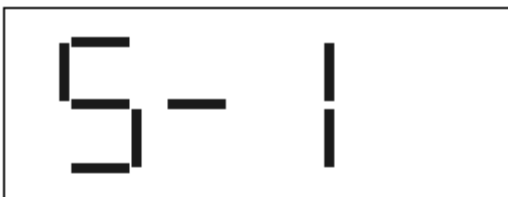

This message present for failures of the sensors such as short circuit, breaking down of wire, abnormal wiring, and back to normal condition when the failures are removed.

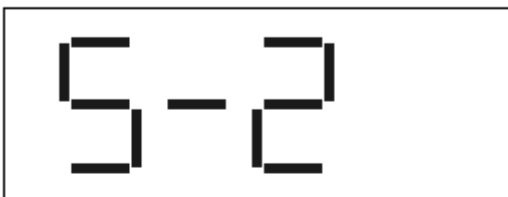

Shown when occur inner failure of transmitter operation, and back to normal condition when the failures are removed.

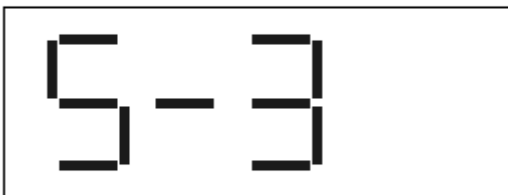

Shown when inner parameter's data error, back to normal condition when the failures are removed.



Shown when set abnormal sensor type, and back to normal condition when the failures are removed.



Shown the polling address when multi-modes

Below messages present for setting Zero / Span using the buttons on the top of transmitter. First two messages are normal setting conditions and following two messages are abnormal setting conditions.



Shown when normally set Zero the current value..



Shown when normally set Span the current value



Shown when the target Zero input value is over sensor limit(Minimum Span) in case Span is +, and the input value must be less than sensor limit(Minimum Span)

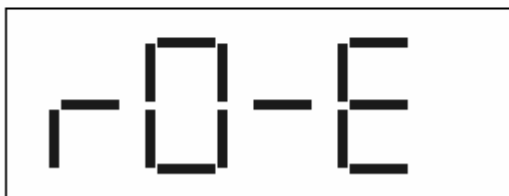

Shown when prohibit writing on EEPROM of inner CPU. In this case, Zero and Span setting is impossible(Permit after EEPROM writing enable setting)

## Chapter 4 Installation

### 4.1 Overview

The information in this chapter 4 covers installation considerations. Dimensional drawings for Model ATT-2100 variation and mounting configuration are included in this chapter.

### 4.2 Safety Message

Procedures and instructions in this chapter may require special precautions ensure the safety of the personnel performing the operation. Information that raises potential safety issues is indicated by a warning symbol(▲). Refer to the following safety messages before performing an operation proceeded by this symbol.

### 4.3 Warning

#### ▲ Warning

Explosion can result in death or serious injury :

- ◆ Do not remove the transmitter covers in explosion environments when the circuit is alive.
- ◆ Check transmitter to install according to Intrinsically safe regulation before HHT connect to Transmitter in explosive environment.
- ◆ Check environment is fully engaged to the transmitter's hazardous location certificate
- ◆ Both transmitter covers must be fully engaged to meet explosionproof requirements

#### ▲ Warning

Electrical can result in death serious injury:

- ◆ The qualification which is educated only the person whom it prepares will be able to establish the transmitter.

#### ▲ Warning

Process leaks can cause death or serious injury:

- ◆ Install and tighten before applying pressure. If you don't like this, it can cause process leaks.

#### ▲ Warning

Electrical shock can result in death or serious injury. If you install high voltage environment or false condition, power line and lead will be appressed high voltages.

- ◆ Avoid contact with the leads and terminals.

### 4.4 Commissioning on the bench with Hand-Held Terminal

After and before installation, You can handle upon commissioning. However, for correctly handling and knowing the function, before installation you have to handle upon commissioning on the bench with Hand-Held Terminal.

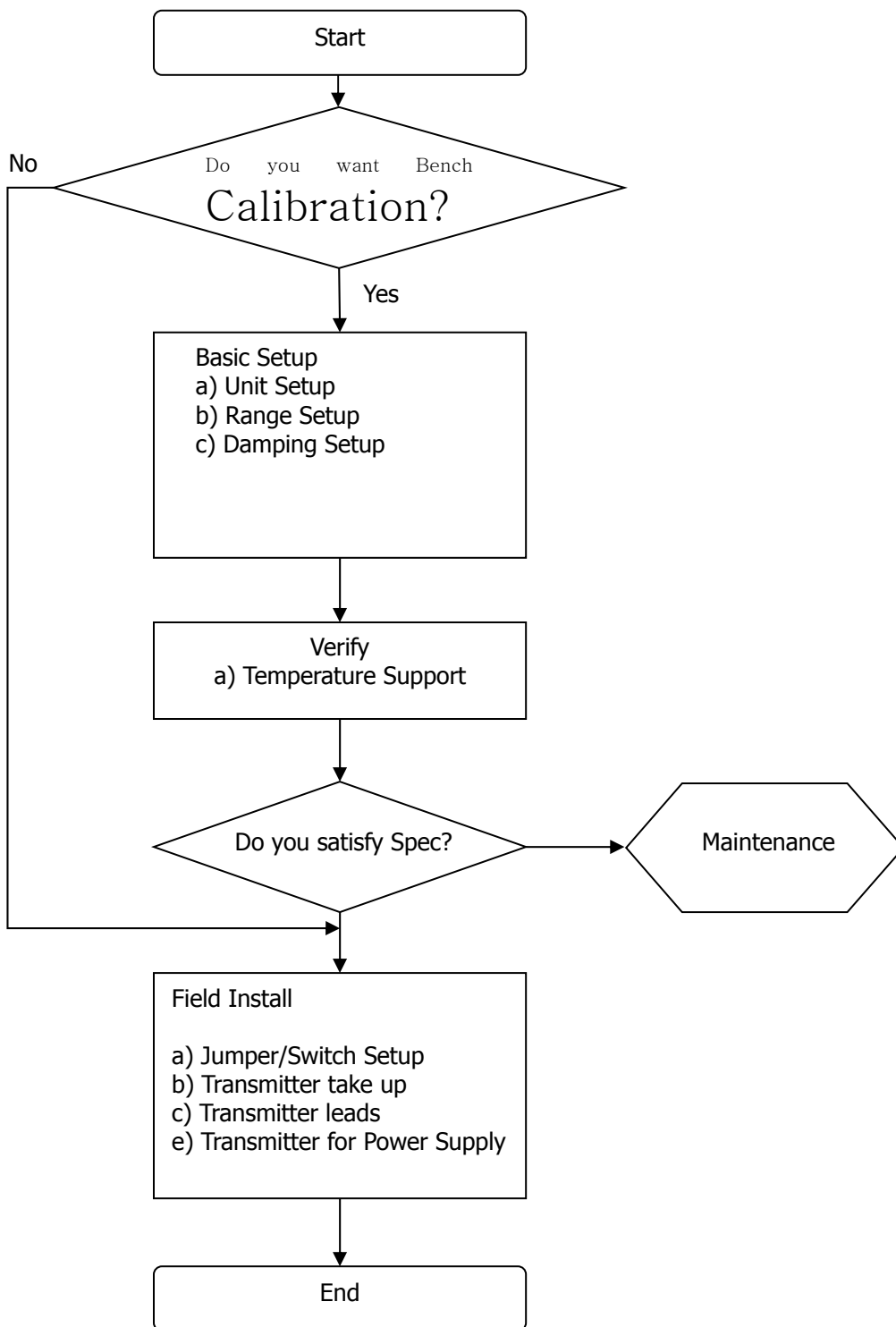

Figure 4-1 Installation Flow Chart

## 4.5 General Considerations

This transmitter uses temperature sensors. It transfer electrical signal minutely to 4~20mA analog signal. Thus mount the transmitter close to the process and use a minimum of sensor length to achieve best accuracy. However keep in mind the need for easy access, safety of personnel, practical field calibration, and a suitable transmitter environment. In general, install the transmitter so as to minimize vibration, shock, and temperature fluctuations.

## 4.6 Electrical Considerations (Power Supply)

The transmitter housing composes of two parts. One side is electronics circuit, and other side is Terminal Block. Terminal Block side is transmitter's frontside and is indicated " Field Terminal" in transmitter housing external. Open this side's housing cover, there is Terminal Block in housing inside. Consider to this Terminal Block polarity, connect to Transmitter's Power Supply. Configurator supported HART connects to "COMM" pin in Power Supply downside. In the field Indicator connects to "TEST" pin.

## 4.7 Power Supply

In the transmitter's power supply Input Current Voltage is currently DC voltage between DC 11.9 volt ~ 45 volt and power supply's ripple is not up to 2%. Loop resistance means all resistor sums in loop.

In case of using Intrinsic Safety Barrier, same includes resistor of barrier.

$$\text{Max. Loop Resistance } [\Omega] = 41.7 \times (\text{Power Supply} - 11.9) [\text{ohm}]$$

Here, loop resistance is preferable at 250 ~ 600 $\Omega$  (24 Vdc) for the HART communication.

## 4.8. Wiring

### 4.8.1 Caution of Wiring

- (1) Install cable in the far from electrical noise resources like capacitive transformer, motors power supply as soon as possible.
- (2) Before wiring put out electrical lead connect cap.
- (3) All screw-lined portions paste suture for waterproof. (It promotes the silicon type that is not hardened.)
- (4) Don't lead signal line to power line in same duct for no received noise signal.
- (5) The explosion-proof transmitter in order to maintain the explosion-proof quality of the corresponding transmitter effectively follows in the demand explosion-proof specification that is provided and must be lead.

## 4.8.2 Selecting the Wiring Materials

- (1) Use over 600V PVC shielded wire or standard lead line of same class or cable. (In order to ensure proper communication use 24 AWG or larger wire, and do not exceed 1500 meters.)
- (2) Use the shielded wire in electrical noise effected area.
- (3) At the higher or lower temperature area than ambient temperature it uses the wire or the cable that is suitable like that temperature.
- (4) You have to use suitable wire, cable in environment like oil, solvent, toxic gas or liquid.
- (5) Terminal process of lead line must use to not soldered terminal lug. Recommend isolating lead end terminal using contract tube.

## 4.8.3 Connections of External Wiring to Transmitter Terminal Box

Wiring method is following this.

- ▲ (1) Open the housing cover indicated "FIELD TERMINAL". In explosion environment when circuit is powered on, don't open the covers.
- ▲ (2) Connect the power supply in the terminal indicated "+PWR"(left terminal) and "-" power supply in the central terminal. Don't connect "+" power supply in "+" terminal of the point indicated "TEST". It will be damage to test diode used to connecting TEST terminal.
- (3) Seal and close the non-using Conduit Connection Part for severe humidity and explosion on the terminal box of housing.
- (4) Transmitter power is supplied to Signal Wiring. So, don't install near to Signal Wiring with Power Wiring or near to Power Apparatus. In case of ground signal, ground the signal loop's one side and other side is not grounded. Promote to ground "-" side of power.
- (5) For the better adjustment completely turn Screw terminal.
- (6) Again close the transmitter cover. Specially in case of using in explosion area, you must to satisfy requirement about explosion.

[Note]

Don't supply high voltage (AC power) in transmitter leads. It can be caused damages to transmitter.

- (7) You have to connect 250~600 ohm Loop Resistor in Current Loop(between Power Supply and Transmitter) for HART Communication HART. Following Figure 4-2 is about connection of Current Loop.

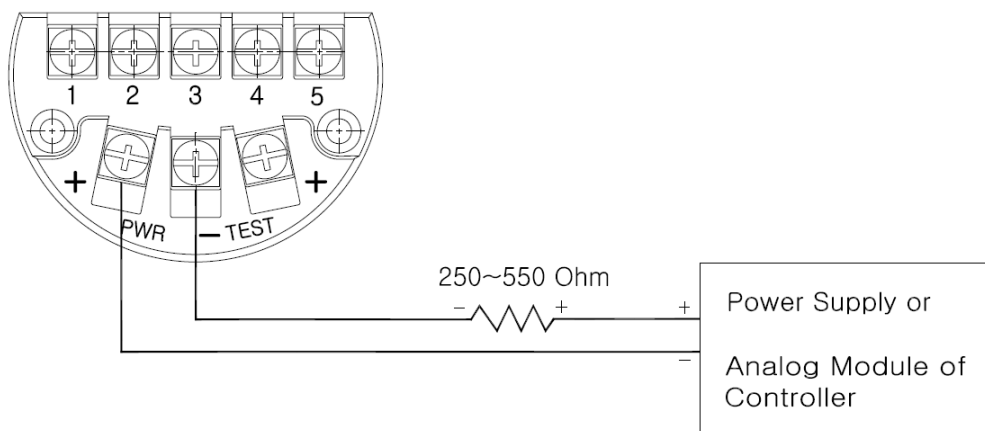

Figure 4-2. Connection of Current loop

■ Wiring

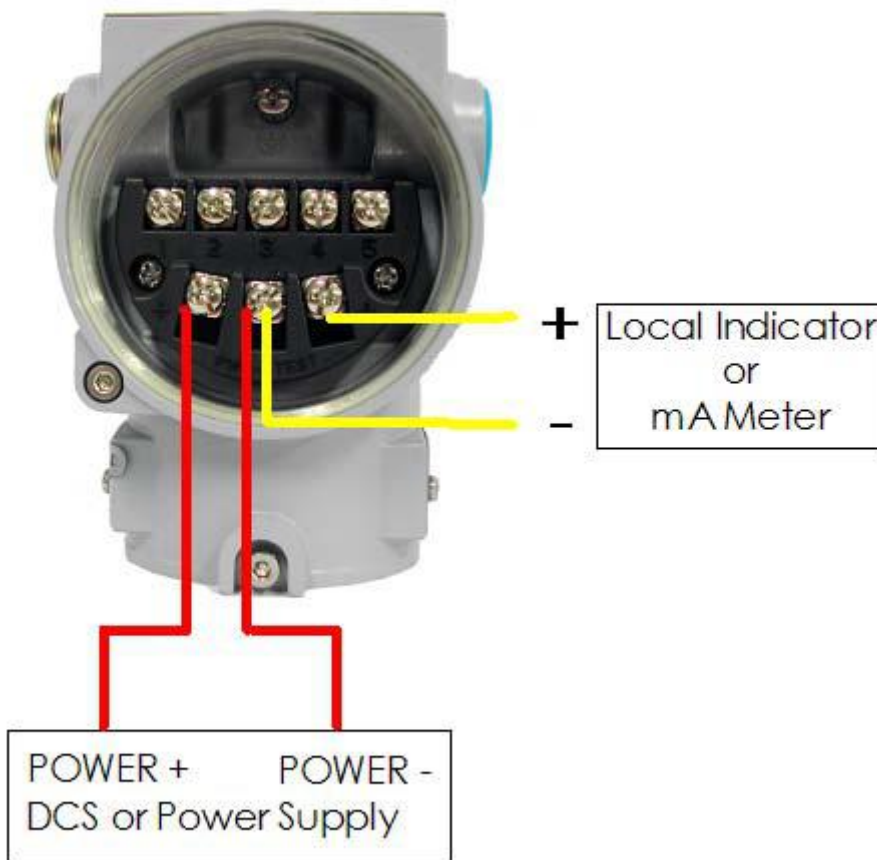

Figure 4-3. Picture of Terminal Board of Transmitter

<b>▲ Warning</b>
Explosion can result in death or serious injury: <ul style="list-style-type: none"><li>◆ Do not remove the transmitter covers in explosion environments when the circuit is alive.</li><li>◆ Before connection HHI in explosion zone, confirm that the configure device has to be installed by intrinsic safety regulations.</li><li>◆ Check environment is fully engaged to the transmitter’s harzadous location certificate</li><li>◆ Both transmitter covers must be fully engaged to meet explosion proof requirements</li></ul>



### 4.9 Loop Configuration

AUTROL Series Transmitters use a two-wire system for power supply, 4~20mA analog signal transmission and HART digital transmission. DC Power Supply is required for the transmitter loop. The Transmitter and distributor are connected as shown below.

(1) Non-Explosionproof / Flameproof Type

Hazardous Location Transmitter terminal box <-----> Nonhazardous Location Distributor (Power supply unit) Receive Instrument

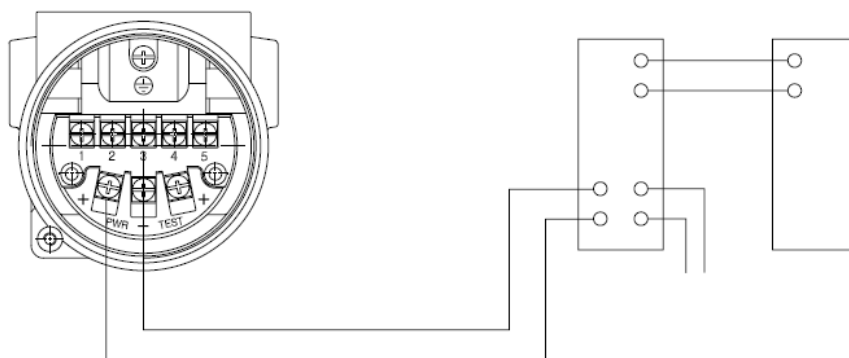

(2) Explosionproof Type

Hazardous Location Transmitter terminal box <-----> Nonhazardous Location Distributor (Power supply unit) Receive Instrument

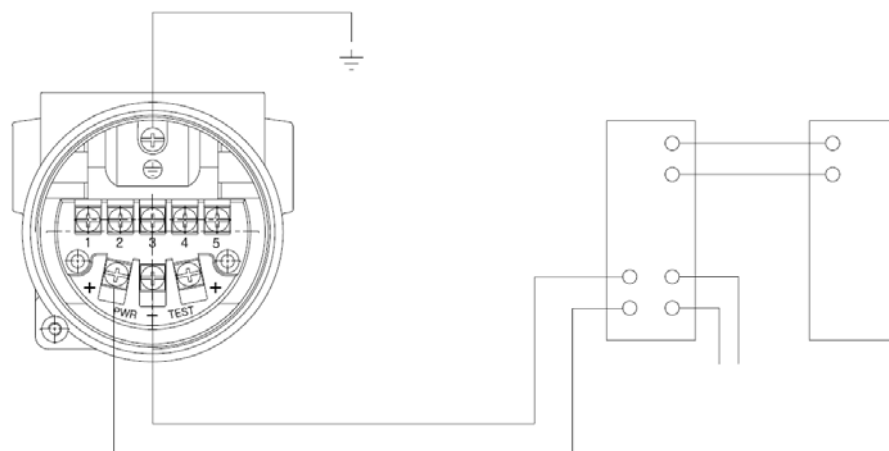

(3) Intrinsic Safety Type (Safety Barrier must be connected to inner Loop)

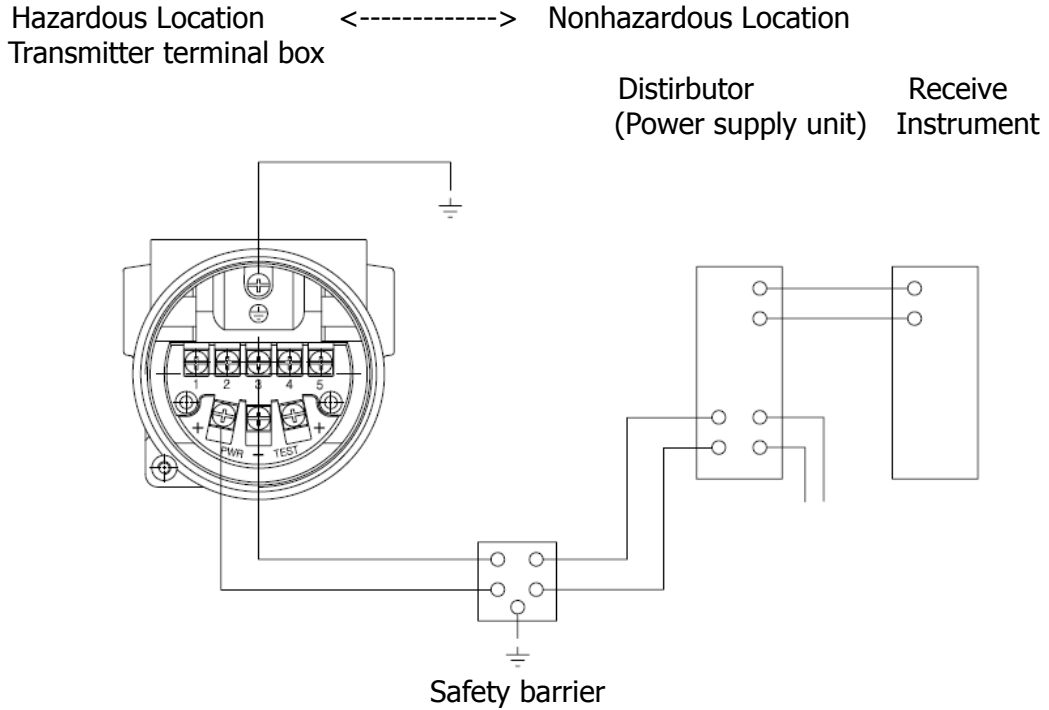

### 4.10 Wiring Installation

1) General-use Type and intrinsically Safe Type make cable wiring using metallic conduit or Waterproof cable glands (Safety Barrier must be connected to inner Loop)

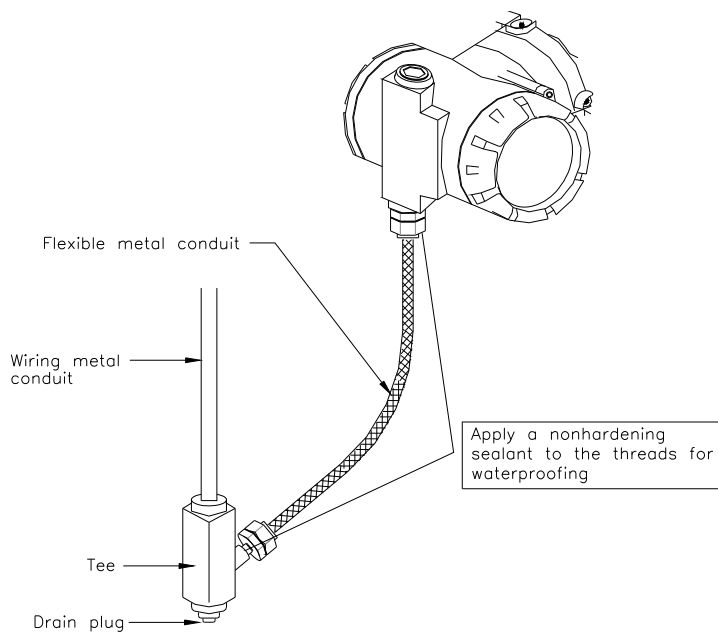

(2) KOSHA Flameproof Type

Wire cables through a flameproof packing adapter, or using a flameproof metal conduit.

(a) Wiring cable through flameproof packing adapter for KOSHA flameproof type (see Figure 4-4b)

- ◇ Use only flameproof packing adapter by KOSHA.
- ◇ Apply a non-hardening sealant to the terminal box connection port and to the threads on the flameproof packing adapter for waterproofing
- ◇ Mounting flameproof packing adapter to the terminal box.
- o. Screw the flameproof packing adapter into the terminal box until the O-ring touches the terminal box wiring port (at least 5 full turns), and tighten the lock net.

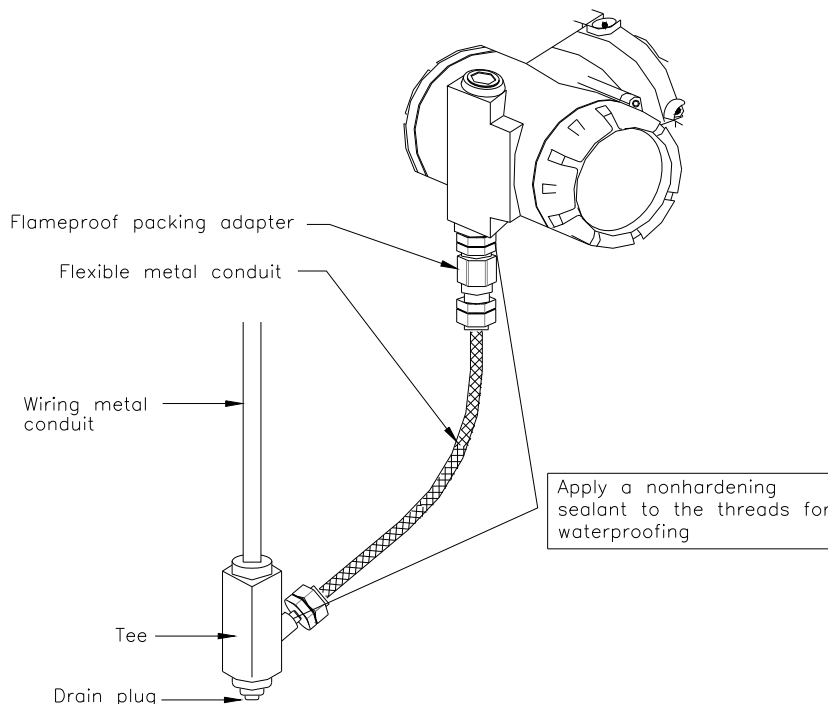

## (b) Flameproof metal conduit wiring

- ◇ A seal fitting must be installed near the terminal box connections port for a sealed construction.
- ◇ Apply a non-hardening sealant to the threads of the terminal box connection box, flexible metal conduit and deal fitting for waterproofing.

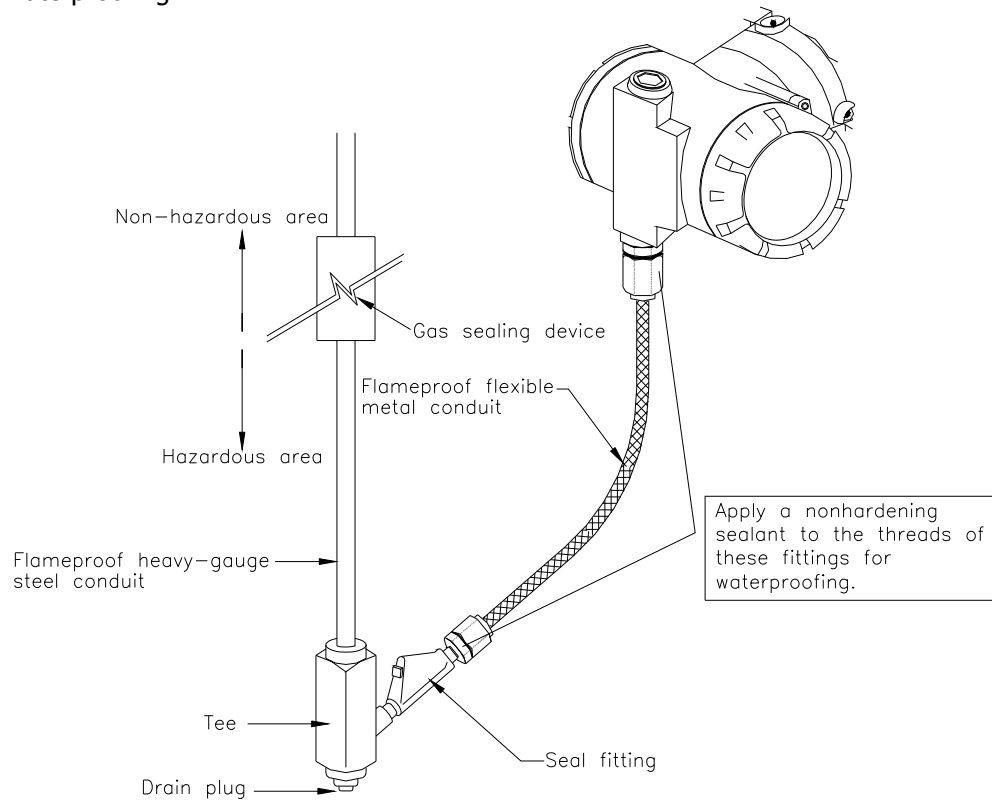

After wiring, impregnate the fitting with a compound to seal tubing.

### 4.11 Grounding

- (a) Grounding should satisfy KS requirements (grounding resistance, 10 Ohm or less). Grounding is required below 10 Ohm for explosionproof and intrinsic safety.

[Note] In case of with Built-in Lightning Protector, Grounding should satisfy Special KS requirements (grounding resistance, 10 Ohm or less)

- (b) There are ground terminal on the inside and outside of the terminal box. Either of these terminals may be used.

- (c) Use 600V grade PVC insulated wire for grounding.

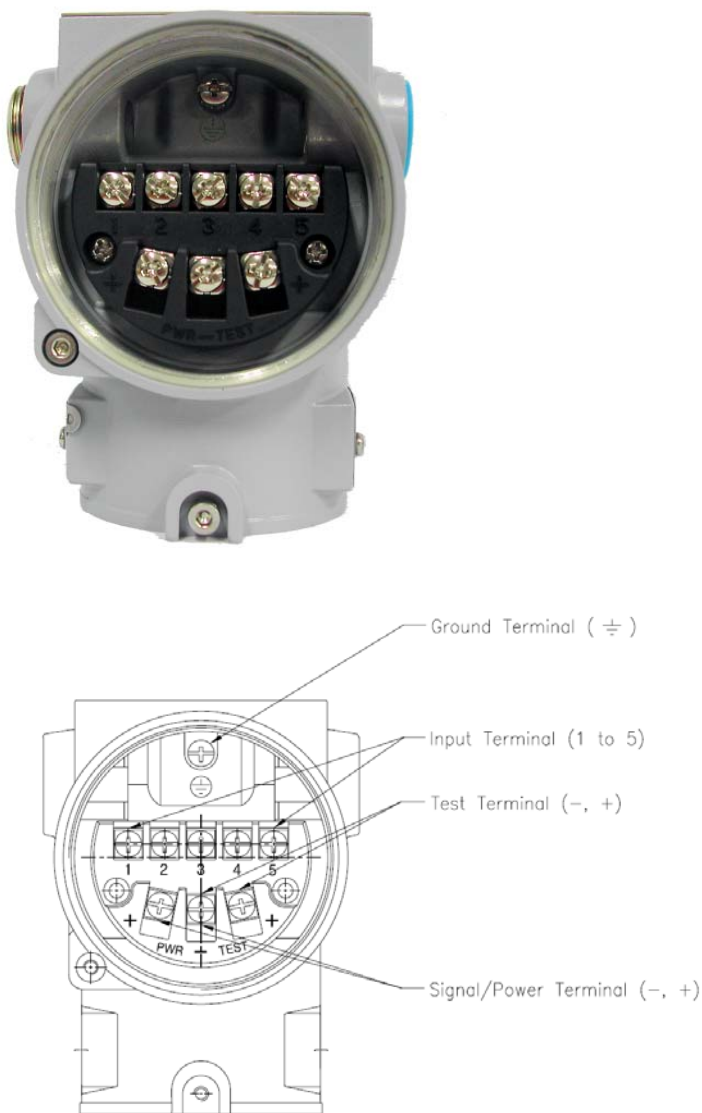

Figure 4-4. Connection of Grounding

## 4.12 Power Supply Voltage and Load Resistance

When configuring the loop, make sure that the external load resistance is within the range in the figure below. Since the voltage of transmitter terminal input is same as follows.

- General Standard : 11.9 to 45 Vdc (for the ATEX 11.9 to 42Vdc)

And maximum loop current is 24mA, Load resistance R:

$$R = (E - 11.9) / 0.022 \quad (E = \text{Power Supply Voltage})$$

[Note] In case of an intrinsically safe transmitter, external load resistance includes safety barrier resistance.

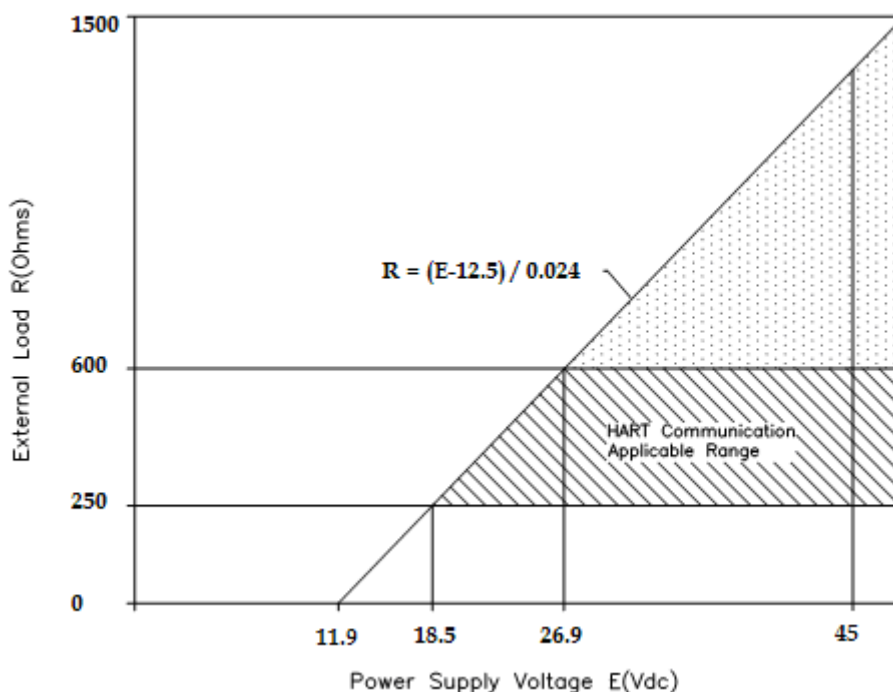
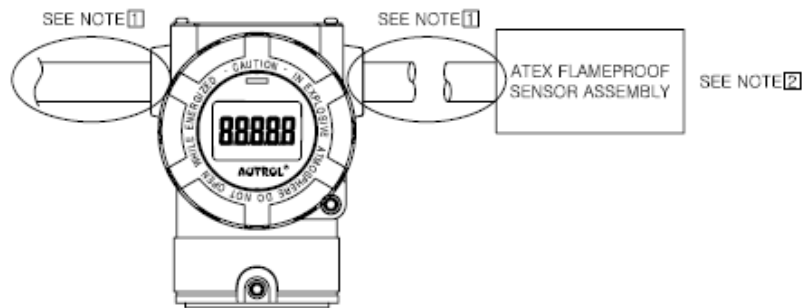
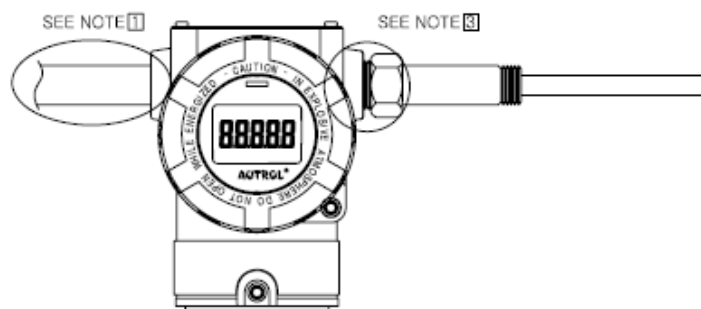

Figure 4-5. HART Communication Applicable Range

## 4.13 Temperature Sensor Installation



REMOTE MOUNT SENSOR



DIRECT MOUNT SENSOR

### NOTE

1. Install per local installation codes. Qualified cable entry or stopping box required.  
(For Using ATEX explosion proof certificate, Must be use ATEX approved cable entry)
2. Temperature sensor assembly must be qualified for appropriate area classification.  
(For Using ATEX explosion proof certificate, Must be use ATEX approved Temperature sensor)
3. Threads must be assembled with loctite thread sealant and have a minimum of five full threads engagement and 8mm axial length engagement.
4. Must use qualified temperature sensor.  
(For Using ATEX explosion proof certificate, Must be use ATEX approved Temperature sensor)
5. It is possible to install temperature sensor both side of housing and bottom of housing considering the installation condition.
6. In the case of detecting high temperature (T6: above 75 °C, T5: above 90 °C, T4: above 125 °C), use the remote type temperature sensor to prevent the influence to transmitter.

## 4.14 Mechanical Considerations

Figure 4-6 is transmitter dimensional drawings of ATT2100.

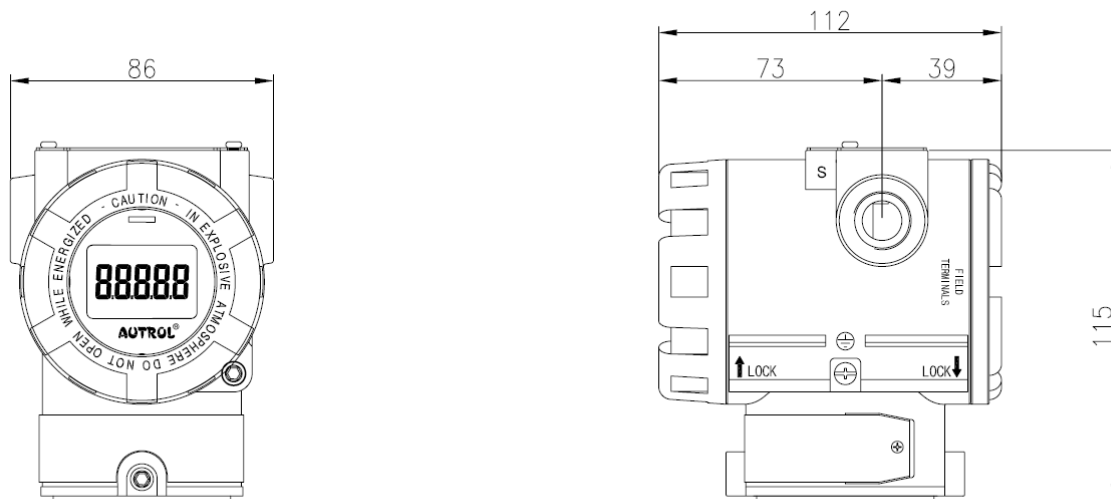

Figure 4-6 ATT2100 Outline Dimension Drawing

### 4.14.1 Mounting

To use the cadence carrier from the environment where the vibration is heavy and must install the transmitter. In the environment where the vibration is heavy you will have to install the transmitter by using an assistant support. In the case of severe vibration, promote to mount on pipe using a mounting bracket as option.

### 4.14.2 Consideration of Transmitter Access

When selecting the establishment location or a place of the transmitter, it treats the transmitter it probably is a location that is convenient must consider.

- ① Rotation of housing: housing can be rotated up to 90°.
- ② Terminal sides of transmitter: location ease us terminal space where be able to pull out transmitter cover
- ③ Circuits side of transmitter: the space where there is a possibility of treating a electronic circuit / the space where be able to pull out transmitter cover / If LCD meter is installed, it requires extra space.



## 4.15 Environmental Considerations

### 4.15.1 Effect of Ambient Temperature

You have to install at  $-40^{\circ}\text{C}\sim 85^{\circ}\text{C}$ , operating ambient temperature range. If predicted heat seems to exceed or equivalent to ambient temperature range limit, you have to consider additional method to cutoff the process heat.

### 4.15.2 Environment of toxic, moisture

Housing of ATT-2100 can be protected to moisture or toxic material. Electronic circuit side is separating from terminal side. When O-ring Seal cover covers, it is intrinsic safety. But, some drip could penetrate to the housing of transmitter through conduit pipeline. Therefore, transmitter should be set up over the position of conduit pipe for preventing drip.

### 4.15.3 Installation of dangerous place

Transmitter is designed to explosion-proof housing. Installation environment of transmitter must be confirmed explosion-proof specification.

## Chapter 5 On-line Operation

### 5.1 Overview

This chapter describes to configure function of ATT2100 SMART Temperature Transmitter. Transmitter can be configured to On-Line or Off-Line mode. In On-Line Configuration Mode, you must connect configuration such as HHT (Hand Held Terminal), etc. Configuration data inputs in Working Register of HHT and this data is sent to corresponding transmitter.

### 5.2 Safety Message

Send operation. Do specially notice for safety of operator. In damage and place required specially safety, We indicate Warning symbol(▲). When you operate work of Warning symbol, follow Safety Message.

#### 5.2.1 Warning

▲ Warning
<p>Explosion can result in death or serious injury:</p> <ul style="list-style-type: none"> <li>◆ Do not remove the transmitter covers in explosion environments when the circuit is alive.</li> <li>◆ Before connecting HHT in explosion zone, confirm that the configure device has to be installed by intrinsic safety regulations.</li> <li>◆ Both transmitter covers must be fully engaged to meet explosion-proof requirements</li> </ul>

▲ Warning
<p>Electrical shock can result in death or serious injury. If you install high voltage environment or false condition, power line and lead will be appeared high voltages.</p> <ul style="list-style-type: none"> <li>◆ Avoid contact with the leads and terminals.</li> </ul>

#### 5.2.2 Configuration current to passive mode

In the case of short Current Loop, send or request data to change transmitter output you must configure Current Loop to passive mode. Don't believe in message indicating HHT, must configure Current Loop to passive mode with other operation.

### 5.3 Configuration Data Review

In case of install transmitter in fact site, before operate transmitter reexamine and certify whether configuration data correspond with fact application environment.

## 5.4 Check Output

Before other handle transmitter to on-line, you must examine and confirm whether transmitter currently operate and suitably configure progress variable.

### 5.4.1 Process Variable

We use two progress variable in ATT-2100 SMART Pressure Transmitter pressure value is Primary Variable and temperature value of pressure value configure SV(Secondary Variable) with fixed value. Moreover this PV value ouputs with 4~20mA analog value.

## 5.5 Basic Setup

You must configure correlation variable for operating currently transmitter.

### 5.5.1 Select Sensor Range

Temperature range to measure is depended Range Code of sensor. This value is classified from Temperature sensor module automatically.

### 5.5.2 Set Output Units

Select from the following engineering units:

Unit: °C, °F, °R, °K, etc

### 5.5.3 Rerange

Set the Zero and Span of 4~20mA analog output.

## 5.6 Detailed Setup

### 5.6.1 Set Fail Mode

When sensor is wrong or microprocessor of transmitter doesn't operate normally in order to outputs current value of High or Low.

### 5.6.2 Set Damping Time

The sensor input value changes the response time of the transmitter to smooth variations in output readings caused by rapid changes in input. Determine the appropriate damping setting based on the necessary response time, signal stability, and other requirements of the loop dynamics of your system. The default damping value is 1.0 seconds, and can be reset to damping values between 0 and 60 seconds.

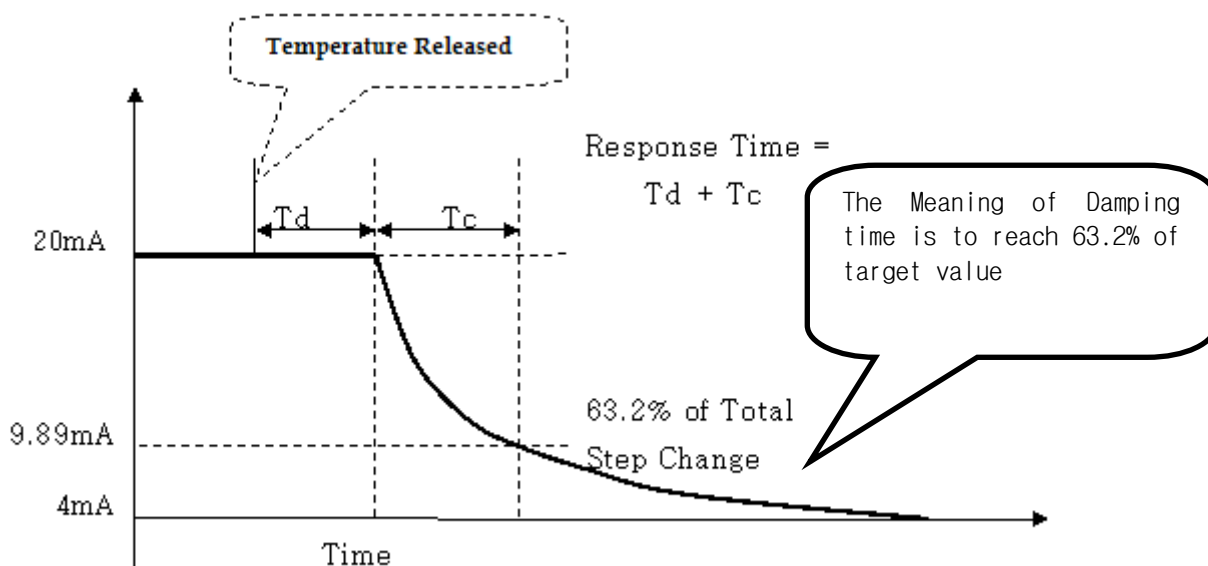

## 5.7 Configuration of Information Variable

### 5.7.1 Set Tag

Tag variable is better easy method to classify to transmitter in multi transmitter install environment. Tag Character can be used to 8 word of English/number.

### 5.7.2 Set Messages

When use several transmitter, user can define for classification each transmitter and use 32 words of English/number. This message is saved in EEPROM of transmitter.

## 5.8 Configuration of Breakdown Diagnostic Function

### 5.8.1 Loop Test

The Loop Test verifies the output of the transmitter, the integrity of the loop, and the operations of any recorders or similar devices installed loop. Perform the following procedure for a loop test.

- ① Connect a reference meter to the transmitter.
- ② Select the Loop Test of HHT and operate the Loop Test.
- ③ Select output current ( 4mA/20mA/etc )
- ④ If the readings match, then the transmitter and the loop are configured and functioning properly. If the readings do not match, then you may have the current meter attached to the wrong loop, there maybe a fault in the wiring, the transmitter may require an output trim, or the electrical current meter may be malfunctioning.

## 5.9 Calibration

Scaled system implement by calibrating the transmitter. Trim function have several function for the calibration. Smart transmitters operate differently than analog transmitter. A Smart transmitter uses a microprocessor that contains information about the sensor's specific characteristics in response to pressure and temperature inputs for calculating Process Variable. The trim and rerange functions also differ. Reranging sets the transmitter analog output to the selected upper and lower range points and can be done with or without an applied pressure. Reranging does not change the factory characterization curve stored in the microprocessor. Sensor trimming requires an accurate pressure input and adds additional compensation that adjusts the position of the factory characterization curve to optimize transmitter performance over a specific pressure range. Rerange functions provides ability to readjust the 4~20mA points sensor inputs.

### 5.9.1 Sensor Trim

The Sensor Trim the transmitter sensor input signal convert A/D to lead and how it interprets the values which it inputs with digital the contents of such interpretation and it is regarding to change is connected actually in the sensor which in order to correspond.

There are three waysto trim the sensor : Sensor zero trim, full trim and zero adjustment.

Sensor zero trim is a one-point adjustment typically used to compensate for mounting position effects or zero shifts caused by static pressure.

Two point trim is a full sensor tirm, in which two accurate end-point pressure are applied(equal to or greater than the range values), and all output is linearized between them. You should always adjust the low trim value first to establish the correct offset.

### 5.9.2 DA (Digital to Analog) Trim

When the D/A trim convert sensor input signal to 4~20mA output, this ouput value scale minuteness. Cyclic you recommend to scale analog output for maintain scale. This function can manage the error about analog conversion if digital value for loop current output.

## Chapter 6 Maintenance

### 6.1 Overview

This chapter describes breakdown diagnostic and maintenance.

### 6.2 Safety Message

When operation, it requires specially notice for the safety of operator. Information that raises potential safety issues is indicated by a warning symbol(▲). Refer to the following safety messages before performing an operation proceeded by this symbol.

#### 6.2.1 Warning

##### ▲ Warning

Explosion can result in death or serious injury:

- ◆ Do not remove the transmitter covers in explosion environments when the circuit is alive.
- ◆ Before connecting HHT in explosion zone, confirm that the configure device has to be installed by intrinsic safety regulations.
- ◆ Both transmitter covers must be fully engaged to meet explosion-proof requirements

##### ▲ Warning

Electrical shock can result in death or serious injury. If you install high voltage environment or false condition, power line and lead will be apprered high voltages.

- ◆ Avoid contact with the leads and terminals.

##### ▲ Warning

Electrical can result in death serious injury:

- ◆ The qualification which is educated only the person whom it prepares will be able to establish the transmitter.

##### ▲ Warning

Process leak can result in death serious injury:

- ◆ Before approval pressure install Thermowell or sensor and then close completely. If don't this, it cause process leak.
- ◆ when operating, don't take out Thermowell.

## 6.3 Hardware Diagnostics

If you suspect a malfunction despite the absence of any diagnostic messages on the HHT follow Table 6-1 described here to verify that transmitter hardware and process connections are in good working order.

If you suspect a malfunction despite the absence of any diagnostic messages on the HHT follow Table 6-1 described here to verify that transmitter hardware and process connections are in good working order.

Symptom	Potential Source	Corrective Action
Transmitter Does not Communicate With HART Communicator	Loop Wiring	<ul style="list-style-type: none"> <li>• Check for a minimum of 250 ohms resistance between the power supply and HHT.</li> <li>• Check for adequate voltage to the transmitter. The transmitter always requires 11.9 ~ 45 Vdc.</li> <li>• Check for intermittent shorts, open circuits, and multiple grounds.</li> </ul>
High Output	Sensor Input Failure	<ul style="list-style-type: none"> <li>• Connect HHT and enter the Transmitter test mode to isolate a sensor failure.</li> </ul>
	Loop Wiring	<ul style="list-style-type: none"> <li>• Check for dirty or defective terminals, interconnecting pins, or receptacles.</li> </ul>
	Power Supply	<ul style="list-style-type: none"> <li>• Check the output voltage of the power supply at the transmitter terminals. It should be 11.9 to 45 Vdc in spite of loop scale.</li> </ul>
	Electronics Module	<ul style="list-style-type: none"> <li>• Connect HHT and enter the Transmitter test mode to isolate module failure. Check the sensor limits to ensure calibration adjustments are within the sensor range.</li> </ul>
Erratic Output	Loop Wiring	<ul style="list-style-type: none"> <li>• Check the output voltage of the power supply at the transmitter terminals. It should be 11.9 to 45 Vdc.</li> <li>• Check for intermittent shorts, open circuits, and multiple grounds.</li> <li>• Check for proper polarity at the signal terminals.</li> <li>• In case measuring electric current while digital communication, output appear around <math>\pm 0.013\text{mA}</math></li> </ul>
	Electronics Module	<ul style="list-style-type: none"> <li>• Connect HHT and enter the Transmitter test mode to isolate an electronics mode failure.</li> </ul>
Low Output or No Output	Sensor Element	<ul style="list-style-type: none"> <li>• Connect HHT and enter the Transmitter test mode to isolate a sensor failure.</li> <li>• Check the PV to see if it is out of range.</li> </ul>
	Loop Wiring	<ul style="list-style-type: none"> <li>• Check for adequate voltage to the transmitter. The transmitter always requires 11.9 ~ 45 Vdc.</li> <li>• Check for intermittent shorts, open circuits, and multiple grounds.</li> <li>• Check polarity of signal terminal</li> <li>• Check the loop impedance.</li> </ul>
	Electronics Module	<ul style="list-style-type: none"> <li>• Connect HHT and check the sensor limits to ensure calibration adjustments are within the sensor range.</li> </ul>

## 6.4 Hardware Maintenance

Autrol ATT2100 Smart Transmitters have no moving parts and require a minimum of scheduled maintenance. Both transmitters feature modular design for easy maintenance. If you suspect a malfunction, check for an external cause before performing the diagnostics as discussed later in this section. If you must return failed transmitters or parts, send them to DUON System Co., Ltd. for inspection, repair, or replacement.

### 6.4.1 Test Terminals

The test terminal, marked as TEST on the terminal block. The test and negative terminals are connected to the test terminals; so long as the voltage across the receptacles is kept below the diode threshold voltage, no current passes through the diode. To ensure that there is no leakage current through the diode while making a test reading, or while an indicating meter is connected, the resistance of the test connection or meter should not exceed 10 ohms. A resistance value of 30 ohms will cause an error of approximately 10 percent of reading.

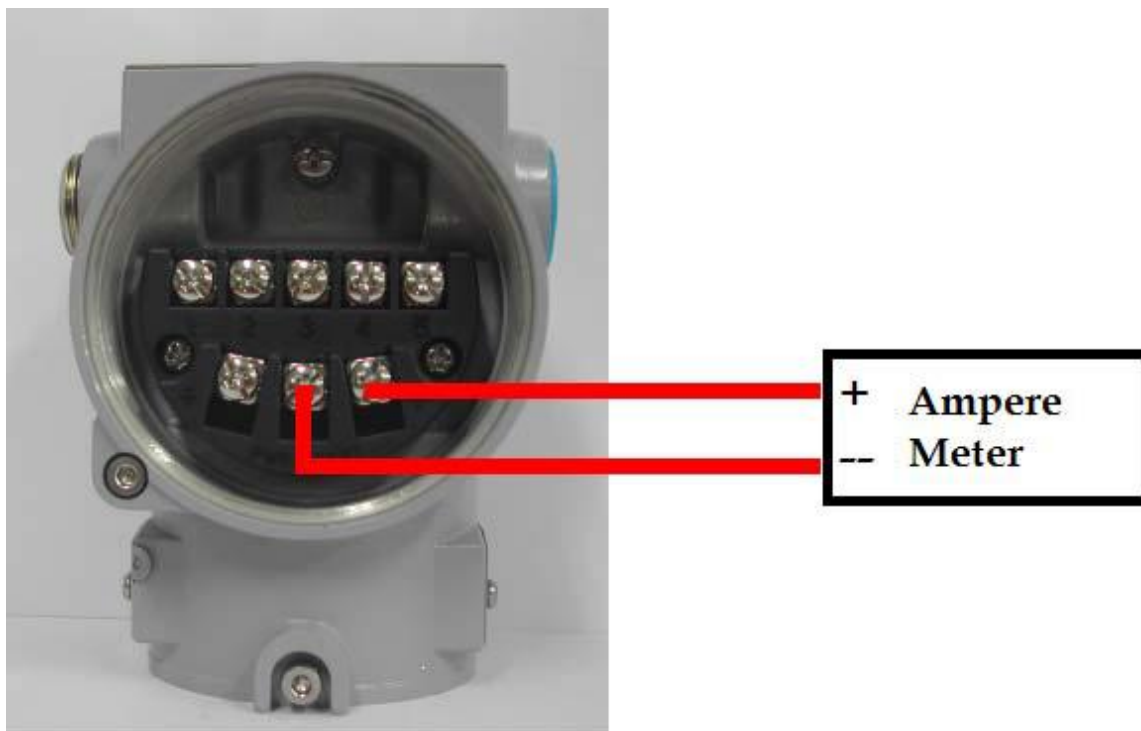

Figure 6-1. Loop Test Terminal



## 6.4.2 Disassembling the Electronics Housing

The transmitter is designed with dual-compartment housing; one contains the electronics module, and the other contains all wiring terminals and the communication receptacles.



Figure 6.2 Structure of Housing

### 6.4.2.1 Disassembling Electronics Module

Use the following procedure to remove the electronics module.

**[Note1]**

The electronics are sealed in a moisture-proof plastic enclosure referred to as the electronics module. The module is a non-repairable unit; if a malfunction occurs the entire unit must be replaced.

1. Disconnect the power to the transmitter.
2. Remove the cover from the electronics side of the transmitter housing (Figure 6.2). Do not remove the instrument cover in explosive atmospheres when the circuit is alive. Remove the LCD meter, if applicable.
3. Remove the two screws that anchor the electronics module to the transmitter housing.
4. Firmly grasp the electronics module and pull it straight out of the housing, taking care not to damage the interconnecting pins.

**[Note2]**

The transmitter EEP-Write Jumpers and failure mode are located on the front of the electronics module. When it will be replaced for a new one, make a same jumper location.



Figure 6-3 Structure of Electronics Module inner Transmitter

### 6.4.2.2 Fail Mode and Jumper Switch of EEPROM-write

Fail-mode and jumper switch of EEPROM-write is located front of electronics module (Refer to Figure 2-2, 2-3)

## 6.4.3 Assembling the Electronics Housing

1) Re-assembling procedure is same as follows.

1. Make sure that Fail-mode and Jumper Switch are set exactly.
2. Insert electronics module in housing
3. Firstly, connect the connector of sensor board with power connector.
  - Mis connection of the two connectors cause wrong output(4~20mA) and effect on power of Transmitter.
  - In case of power connector sandwiched between board and housing, it may cause wrong output signal and effect on power of transmitter.
4. Fix electronics module with 3 screws.
5. Close the cover of housing..

2) Connections of Sensors

Connections with Sensors(Thermocouple, RTD) are as follows.

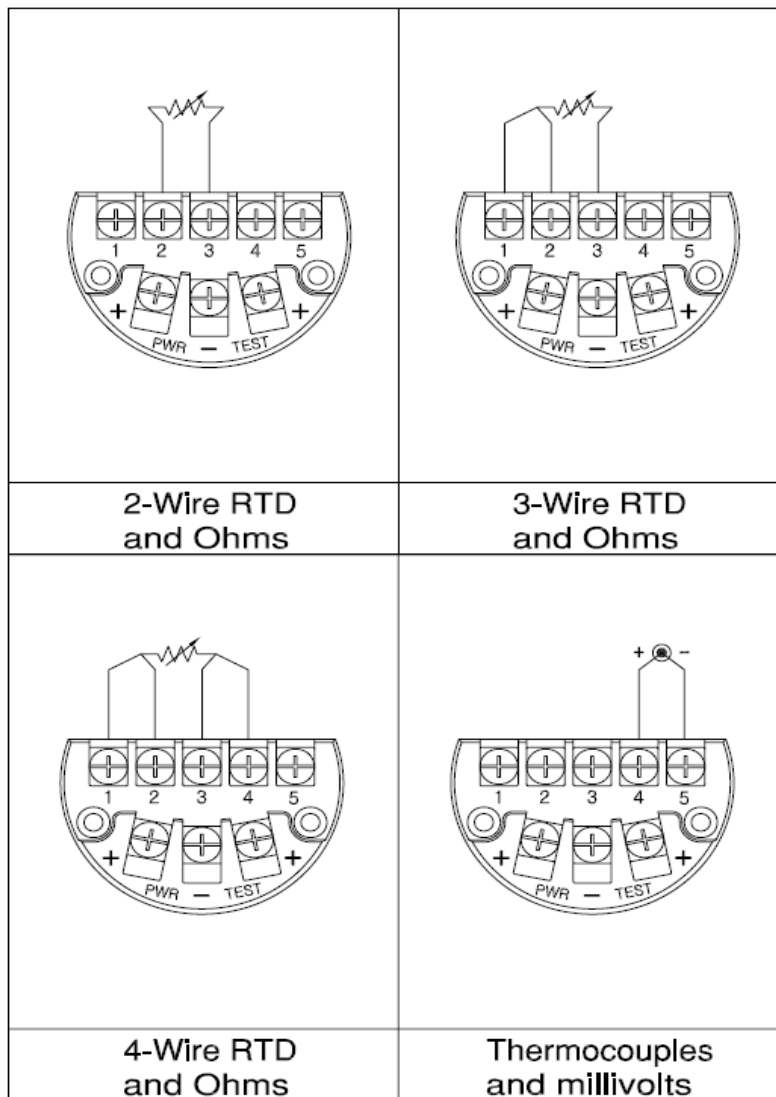

Message	Description	Remarks
<b>ADRE</b>	ADC Initial Error	
<b>2-tr</b>	Zero trim Button Pressed	
<b>2ero</b>	Zero Button Pressed	
<b>span</b>	span Button Pressed	
<b>ber1</b>	Button Input Sequence Error	
<b>2ter</b>	Zero offset value over	
<b>-tr-</b>	Trim Done	
<b>sper</b>	Setting Limit Error When Button Input	
<b>-2e-</b>	Zero Button Function Done	
<b>-sp-</b>	Span Button Function Done	
<b>-20-</b>	Zero Trim or Zero Adjustment Done	
<b>F-RS</b>	Flash Configuration Data Reset	
<b>F-FL</b>	Flash Reset Failure	
<b>-FR-</b>	Flash Reset Done	
<b>A-RS</b>	Analog EEPROM Initializing Start	
<b>A-CP</b>	Analog EEPROM Copy	
<b>A-FL</b>	Analog EEPROM Copy Failure	
<b>-AC-</b>	Analog EEPROM Copy Done	
<b>s-fl</b>	Sensor Fail	
<b>s-op</b>	Sensor over-pressure	
<b>Anbf</b>	Anlog EEPROM fail or Temprature Sensor fail	
<b>EOSC</b>	Oscillator Fault	
<b>FAVE</b>	Flash Access Violation	
<b>NMIE</b>	NMI Interrupt	

## Appendix I

### ATT2100 SMART TEMPERATURE TRANSMITTER LCD DISPLAY CODE